



# RIFTEK

Sensors & Instruments



## PORTABLE RAIL PROFILOMETER

**PRP Series**

### User's manual

22, Logoisky tract, Minsk  
220090, Republic of Belarus  
tel/fax: +375 17 281 36 57  
info@riftek.com  
www.riftek.com

## Contents

1.	Safety precautions and measurement conditions.....	4
2.	CE compliance.....	4
3.	Laser safety.....	4
4.	General information.....	4
4.1.	Controlled parameters.....	4
5.	Basic technical data.....	5
6.	Complete set to be supplied.....	5
7.	Structure and operating principle.....	6
7.1.	Basic components of the device and their functions.....	6
7.1.1.	Laser scanning module.....	6
7.1.2.	Digital readout device (PDA).....	7
8.	Operating principle.....	8
9.	Rail parameters under control.....	8
9.1.	L-parameters.....	8
9.2.	Geometric parameters of the rail under control.....	9
10.	Measurement procedure.....	9
10.1.	Activation.....	9
10.2.	Measurement.....	10
11.	PDA program setting.....	11
11.1.	Measurement type.....	12
11.2.	Units of measurement.....	12
11.3.	Date and time settings.....	13
11.4.	Device selection.....	13
11.5.	Language setting.....	15
11.6.	Synchronization with PC.....	15
12.	Measurement parameters setting.....	16
12.1.	Calculation methods setting.....	16
12.2.	Selection of displayed parameters.....	17
12.3.	L-parameters setting.....	18
13.	Setting the database parameters, tolerances and references.....	18
13.1.	Selection of the current database.....	19
13.2.	Reference profile selection and installation.....	20
13.2.1.	Writing the reference profile to the database.....	20
13.3.	Setting of tolerances.....	20
14.	Updating of PDA software.....	21
15.	Shutdown.....	22
16.	Measurements with database maintenance.....	22
16.1.	Measurement.....	23
17.	Browsing the database.....	24
17.1.	Data filtering.....	24
17.2.	Visualization of the rail profile.....	25
18.	Installation of software on PC and startup.....	26
18.1.	Installation of database support software.....	26
18.2.	Synchronization of PDA and PC.....	26
18.3.	Program startup.....	27
19.	User settings of the program.....	27
19.1.	Parameters setting.....	27
19.1.1.	"Rail parameters" tab.....	28
19.1.2.	"Calculated parameters" tab.....	28
19.1.3.	"L-parameters" tab.....	28
19.1.4.	"Measurement method" tab.....	29
19.1.4.1.	Selection of measurement units.....	29

19.2.	Database settings.....	29
19.2.1.	Setting the path to database.....	29
19.2.2.	Creation of empty database.....	30
19.2.3.	Import of database .....	30
19.2.4.	Language selection.....	31
19.2.4.1.	Preparation and installation of the language support file.....	31
19.3.	Registration data.....	31
19.3.1.	Registration of organizations.....	31
19.3.2.	Registration of operators.....	32
19.3.3.	Registration of reference profiles.....	32
19.3.3.1.	Request and registration of the profile file.....	33
20.	Data exchange between PDA and PC.....	34
20.1.	ActiveSync synchronization.....	34
20.1.1.	Transfer of database file to PC.....	34
20.1.2.	Transfer of language file from PC to PDA.....	35
20.1.3.	Transfer of language file from PDA to PC.....	36
20.1.4.	Transfer of reference profile files from PC to PDA.....	36
20.1.5.	Updating of PDA software.....	37
20.2.	Mass Storage synchronization.....	37
21.	Working with profilograms and wear calculations.....	39
21.1.	Browsing the graph and profile coordinates.....	39
21.2.	"Parameters" tab.....	40
21.2.1.	Selecting a profile to compare.....	40
21.2.2.	Selecting L-parameters values.....	40
21.2.3.	Geometric parameters of the profile.....	41
21.3.	Wear calculation.....	41
21.3.1.	Fast wear calculation.....	41
21.4.	Browsing and saving a profile.....	41
21.4.1.	Export to Excel, DXF, REF.....	42
21.5.	Alignment of profiles.....	42
21.6.	Superposition of profiles.....	43
21.7.	Rescaling.....	43
22.	Scanning and editing of data.....	44
22.1.	Scanning and filtering of data.....	44
22.2.	Editing data.....	45
22.3.	Report preparation.....	46
22.3.1.	Excel-format report.....	47
22.3.2.	Report for printout.....	47
23.	Taking measurements under PC control (without PDA).....	48
23.1.	Calibration.....	49
23.1.1.	Bluetooth-connection.....	49
23.1.2.	Calibration of the profilometer.....	50
23.2.	Measurement by using PC.....	51
23.2.1.	Saving of data.....	51
24.	Annex 1. Charging procedure.....	52
25.	Annex 2. Testing and calibration.....	52
25.1.	Preparation for testing/calibration.....	52
25.2.	Calibration.....	53
26.	Warranty policy.....	54
27.	List of changes.....	54
28.	Distributors.....	55
29.	RIFTEK's measurement devices for railway transport.....	58

## 1. Safety precautions and measurement conditions

- Prior to mounting the profilometer onto the rail, areas of contact and laser scanning of the rail surface should be thoroughly cleaned from dirt.
- When mounting the module on the rail, do not allow heavy shocks of its support against the rail.
- The output windows of the laser sensor must be carefully inspected and cleaned.
- Do not use laser module in locations close to powerful light sources.

## 2. CE compliance

The profilometer has been developed for use in industry and meets the requirements of the following Directives:

- EU directive 2014/30/EU. Electromagnetic compatibility (EMC).
- EU directive 2011/65/EU, "RoHS" category 9.

## 3. Laser safety

The profilometer makes use of a c.w. 660 nm wavelength semiconductor laser. Maximum output power is 1 mW. The device belongs to the 2 laser safety class. The following warning label is placed on the profilometer body:

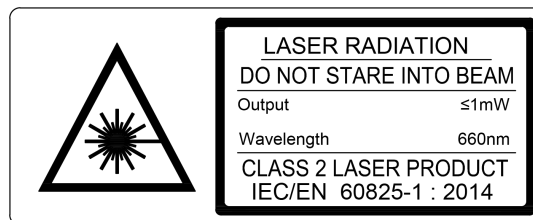

The following safety measures should be taken while operating the profilometer:

- Do not target laser beam to humans.
- Do not disassemble the sensor.
- Avoid staring into the laser beam.

## 4. General information

Portable laser rail profilometer (PRP) is designed for non-contact registration of cross-section of the railhead acting face.

The main functions of PRP are as follows:

- obtaining the information on the cross-section profile of the working railhead surface;
- full profile scanning and analysis of the railhead acting face;
- visualization of the combined graphical images of actual and new cross-section railhead profiles on the display of system unit.

### 4.1. Controlled parameters

- Railhead vertical wear (Hv).
- Side wear (Hh), that is measured 13 mm lower the top of railhead and side wear ( $Hh_{R45}$ ), that is measured at 45 degrees relative to the rail symmetry axes at the point that passes through the center of lateral working fillet.
- Reduced head wear, that is determined as vertical one + the half of lateral wear, namely:  $Hr = Hv + 0,5Hh$  or  $Hr = Hv + 0,5Hh_{L_{R45}}$ .

## 5. Basic technical data

Parameter	Value
Railhead vertical wear, mm	from -15.0 to +20.0
Lateral railhead wear, mm	from -15.0 to +20.0
Redused railhead wear, mm	up to 20.0
Scanning angle inside the rail track, degrees	108
Scanning angle outside the rail track, degrees	108
Measurement error, not more than, mm	±0.1
Scanning time, sec	10-12
Digital readout device (PDA) dimensions, mm	Fig. 5
Laser module dimensions, mm	Fig. 3
Power supply, laser module	3.7V Li-ion battery, 6800mAh
Power supply, PDA	3.7V Li-polymer battery, 3300mAh
Number of measurements that can be taken before battery recharge, not less than	500
PDA memory capacity	100 000 measurements
Interface between a laser module and PDA	Bluetooth

## 6. Complete set to be supplied

Designation	Name	Quantity	Weight, kg
RF303	PDA	1	0.4
RF570	Laser scanning module	1	4.0
RF570.40	Charging device 5V 1.0A for PDA and laser module	2	0.2
RF570.42	Universal cable (USB-port)	1	
RF570.43	Bluetooth-adapter	1	
RF570.30	Packing case	1	1.5
PRP_DB	Database management system (CD)	1	
RF570UM	User's manual	1	
	<b>Calibration tools (optional):</b>		
RF570.20.100	Calibration unit		3
RF570Calibr	Software		

## 7. Structure and operating principle

### 7.1. Basic components of the device and their functions

Figure 1 shows basic components of the device.

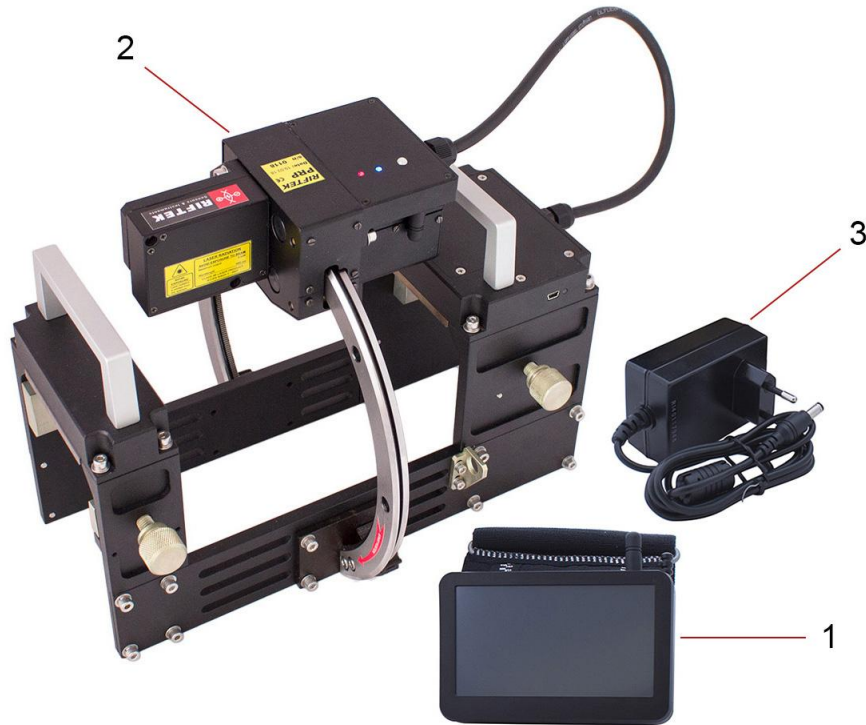

Figure 1

- (1) PDA
- (2) Laser scanning module
- (3) Charging device

#### 7.1.1. Laser scanning module

The module is intended for laser scanning of rail surface.

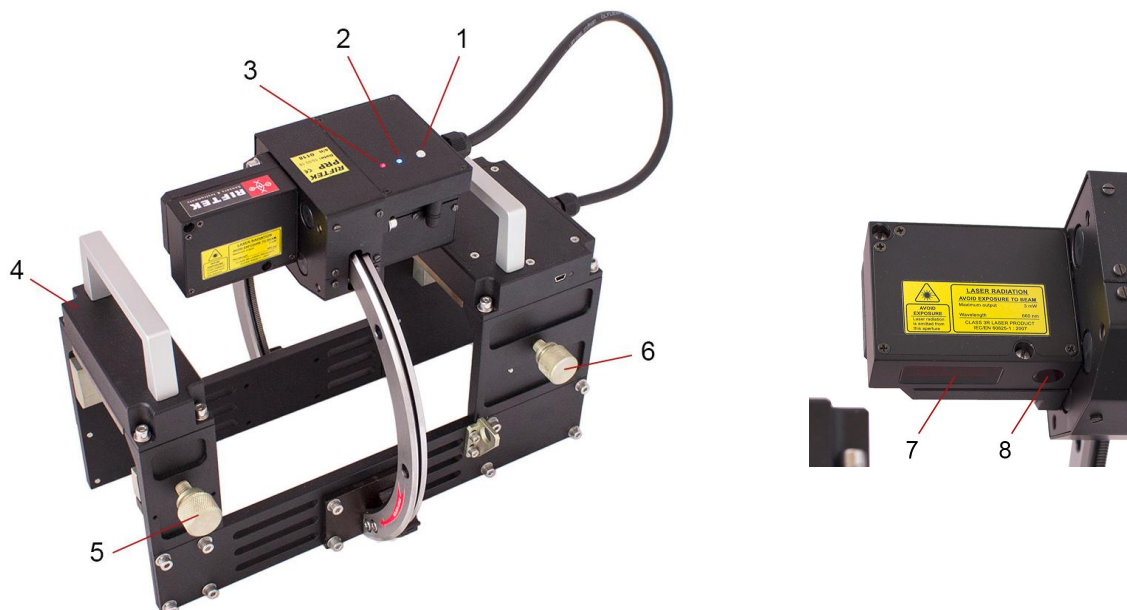

Figure 2

- (1) ON/OFF button
- (2) Indicator of Bluetooth connection (blue LED)
- (3) Indicator of turn ON (red LED)
- (4) Support for mounting of the device on the rail
- (5-6) Clamps for mounting of the device on the rail head
- (7) Input window of laser sensor
- (8) Output window of laser sensor

Overall dimensions of scanning module are shown in Figure 3.

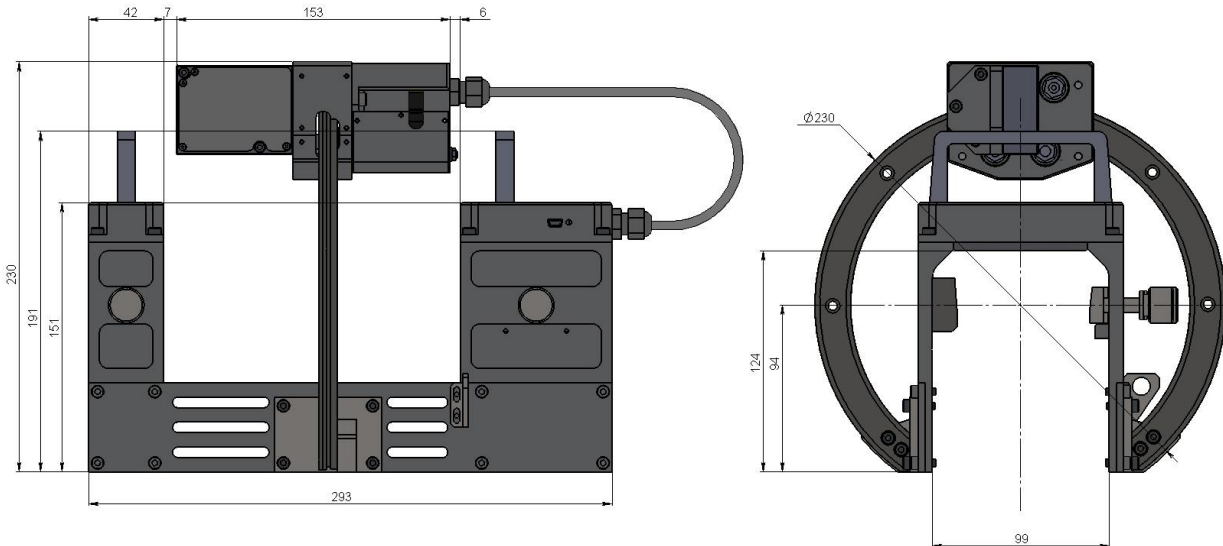

Figure 3

### 7.1.2. Digital readout device (PDA)

Digital readout device (PDA) is designed for control of the laser scanning module, data reception from the scanning module, indication of measurement results, parameter input, and data storage.



Figure 4

- (1) ON/OFF button
- (2) Charging indication, red/blue LED
- (3) Connector to PC USB-port or charging device
- (4) Flash memory card connector
- (5) Stylus
- (6) Bluetooth antenna

Overall dimensions of PDA are shown in Figure 5:

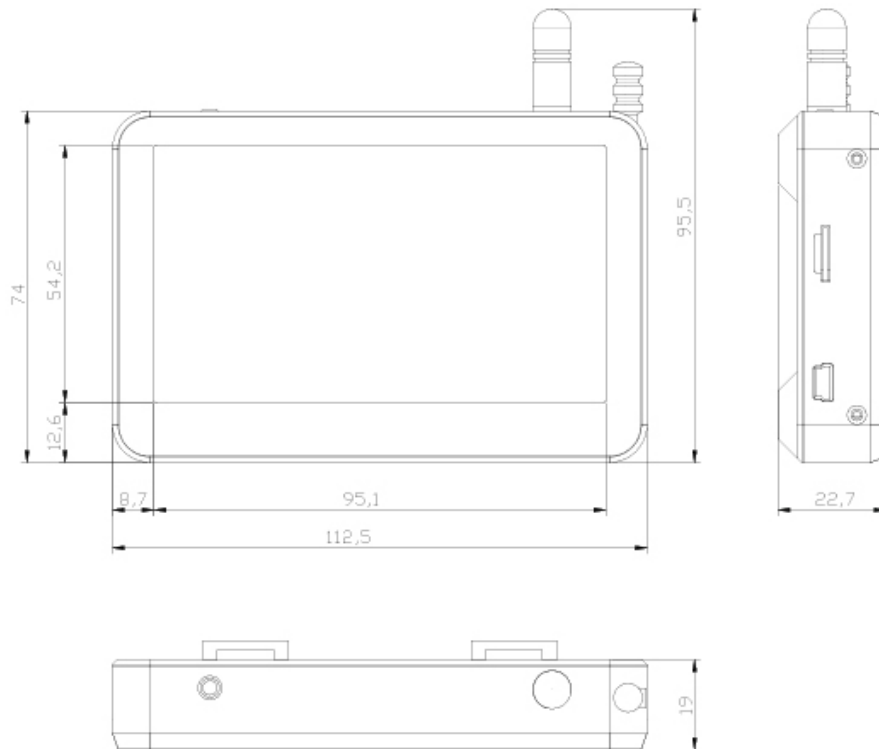

Figure 5

## 8. Operating principle

Operator mounts the laser scanning module onto the railhead to be measured. Having received a command from PDA or PC, the laser module performs non-contact scanning of rail surface. Measurement results (geometric parameters and profile of the surface) are displayed on PDA, can be saved in the PDA memory, and transferred to the PC database. Simultaneously, additional parameters can be saved: date, operator number, permanent way division, track number, rail type, etc.

## 9. Rail parameters under control

### 9.1. L-parameters

Geometric parameters of the rail are calculated automatically after laser scanning of the rail is completed. To calculate geometric parameters, use is made of reference points on the railhead. Location of the reference points is shown in Figure 6 and is defined by **L-parameters**. Values of L-parameters preset in PDA are given in Table 1 and can be changed by user.

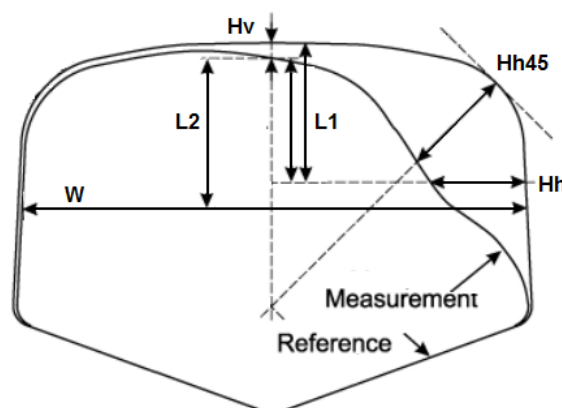

Figure 6



Table 1.

L-parameter	Default value	Description
L1	13 mm	Used for calculation of lateral railhead wear
L2	20 mm	Used for calculation of railhead width

## 9.2. Geometric parameters of the rail under control

The parameters under control and respective calculation methods are given in Table 2.

Table 2.

Parameter	Designation	Calculation method
Railhead vertical wear	Hv	is calculated as a difference between the measured value and nominal value of new rail in direction of rail axis of symmetry
Lateral railhead wear	Hh	is measured at the height of L1 = 13 mm from the rolling surface of rail head
Lateral railhead wear at the angle of 45 degrees	Hh45	is measured at 45 degrees relative to the rail symmetry axis at the point that passes through the center of lateral working fillet
Reduced railhead wear	Hr	is determined as vertical one + the half of lateral wear, namely: $Hr = Hv + 0,5Hh$ .
Reduced railhead wear at 45 degrees	Hr45	is determined as vertical one + the half of lateral wear at 45 degrees, namely: $Hr45 = Hv + 0,5Hh45$
Railhead width	W	is measured at the height of L2 from the rolling surface of rail head

## 10. Measurement procedure

### 10.1. Activation

- Switch on the laser module by pressing the button (1), Fig. 2.
- Switch on the PDA by pressing the button (1), Fig. 4. The PDA screen will show the main program window containing: main menu; indicators of PDA and laser module charging degree; indicator of Bluetooth connection:

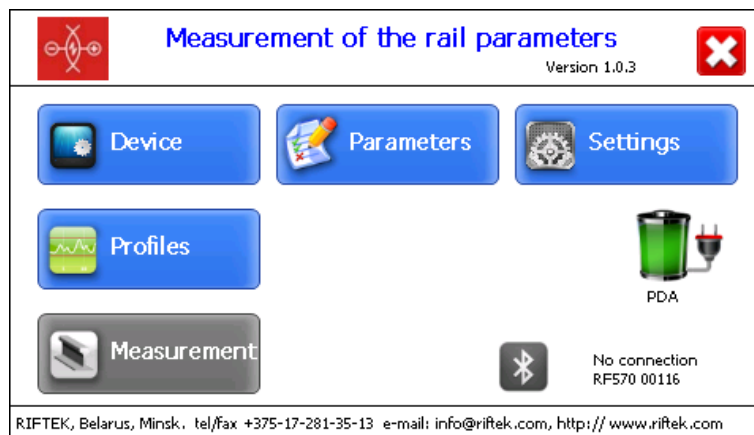

- After the laser module is switched on, some time will pass until automatic wireless communication is set between the profilometer and the PDA, which is accompanied by blinking of a blue LED on the laser module. The LED goes out when the link is established.
- The main window of the program is updated:

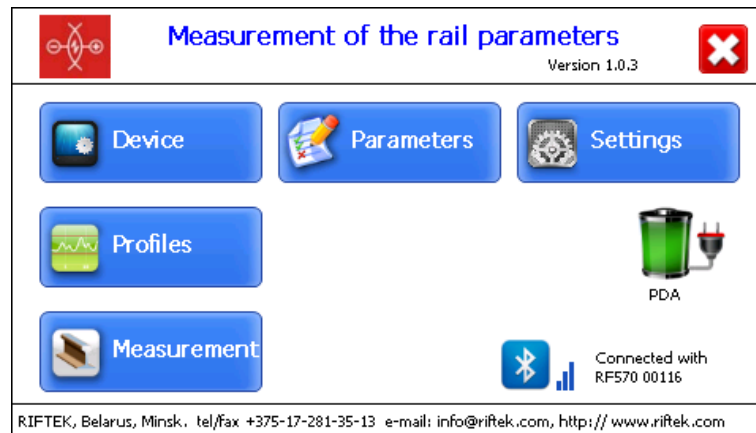

The **Measurement** button, indicator of Bluetooth connection, laser module serial number and charging degree are active.

## 10.2. Measurement

There are two types of measurements:

1. Measurements without saving the results to database.
2. Measurements with saving results to database.

The measurement procedure by using type 2 is described in par. [16](#). How to select the measurement type, see par. [11.1](#).

Measurement by using the scheme (type 2) is used for full-featured work with the profilometer with maintaining the database of measurements.



### Attention!

When installing the laser scanning module onto the wheel, avoid of strong impacts of its supports, because it can lead to incorrect operation of the profilometer.



You need to inspect periodically the output window and basic supports of the laser scanning module and to clean them of dirt.  
Do not clean the glass by using abrasive and aggressive cleaning agents.

To perform the measurement, it is necessary to:

- Fix the laser module on the rail by means of special clamps.



To reduce the scanning time, you can manually move the carriage to the start position.

- Press the **Measurement** button on the PDA display.
- With the **Measurement** button pressed, the laser module will scan the rail surface. During scanning time of about 10-12 seconds, red LED is lit.
- When scanning is completed, the PDA will show values of measured parameters selected for presentation:

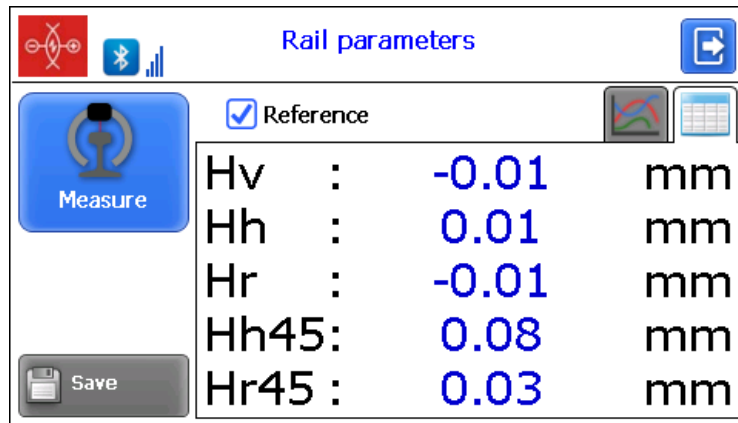

- To look at the rail profile, press the **Profile** button , and the PDA will display the scanned rail profile as well as measured parameters:

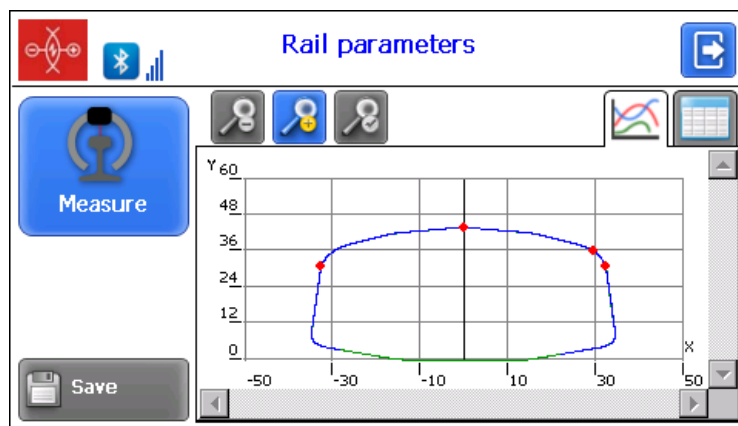

## 11. PDA program setting

The **Device** window:

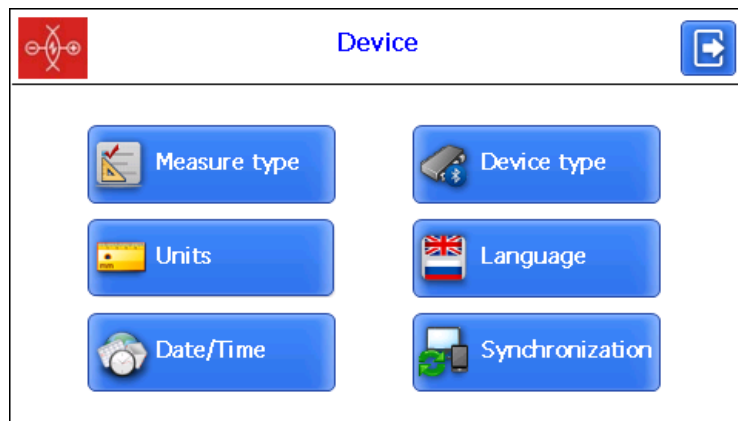

Button	Assignment
Measure type	Measurements with / without saving results to database
Units	Millimeters/inches
Date/Time	Date/time setting
Device type	Device selection
Language	Language selection
Synchronization	Synchronization with PC

## 11.1. Measurement type

Two measurement types are available:

1. Rapid measurements without saving the results.
2. Measurements with saving results to database.

To set the measurement type, press the **Measure type** button. Then select the measurement type: **Rapid measurement** or **Measurement with saving**. Press the **Save** button.

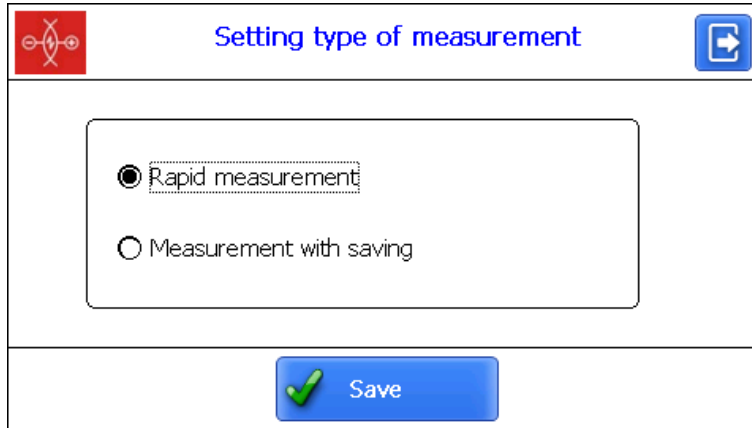

**12**

## 11.2. Units of measurement

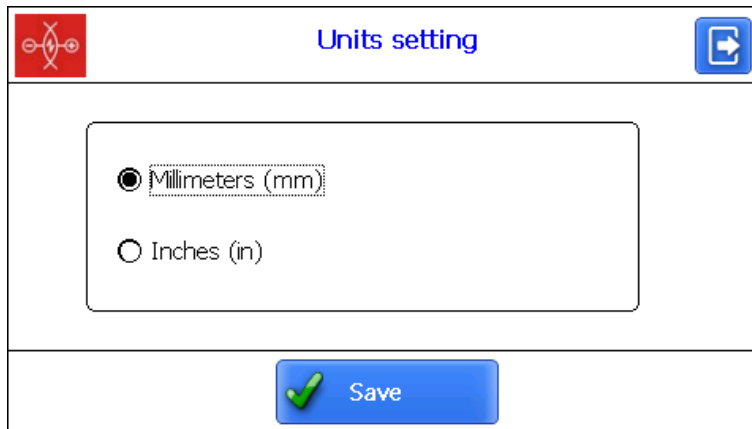
All parameters as well as measurement results can be presented in the Metric system (millimeters), or in the English system of units (inches). To set the units of measurement, press the **Units** button. Then select **Millimeters (mm)** or **Inches (in)**, and press **Save**.



### 11.3. Date and time settings

Press the **Date/Time** button and set the date and time by using the buttons  . Press the **Save** button.

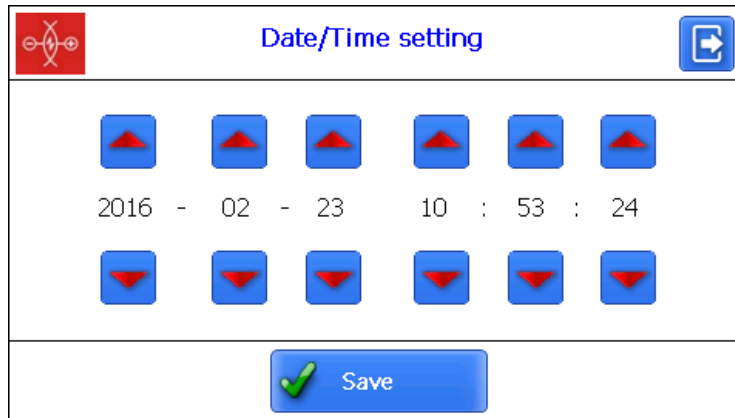

### 11.4. Device selection

The PDA Bluetooth-connection is automatically configured to work with the laser scanning module supplied with the PDA.

To connect another device, press the **Device type** button. You will see a list of available devices (with which the connection has been established earlier, and which have been saved in the PDA memory):

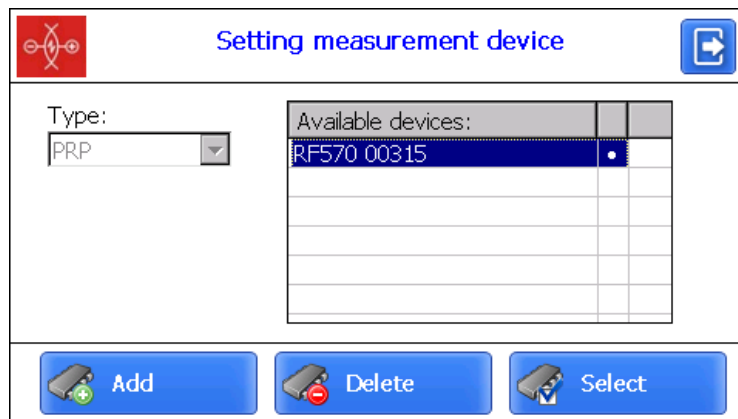

If the needed device is in the list, you can select it and press the **Select** button. The PDA will try to connect to the selected device.

To add a new device, press the **Add** button. The **Device searching** window will appear:



To search for devices, press **Start** and wait for the search to complete:



Name	Address

0 Devices found

Detected devices (with their serial numbers) will appear on the screen:



Name	Address
RF570 00116	00:12:6f:2e:de:e2

1 Devices found

Select the device and press **Save**.

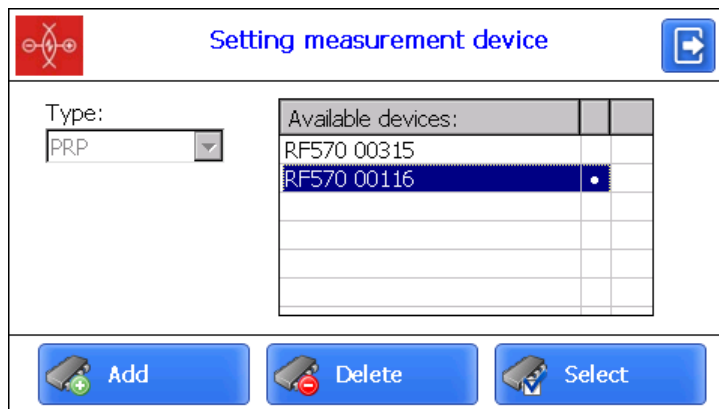

Available devices:	
RF570 00315	
RF570 00116	

You can delete the device that you do not use anymore by pressing the **Delete** button.



Delete this device?

Yes No

## 11.5. Language setting

It is possible for the user to change the program language, form his own language support files as well as change/edit the terminology used.

To select the language, press the **Language** button. Next, select the required language support file and press the **Select** button.

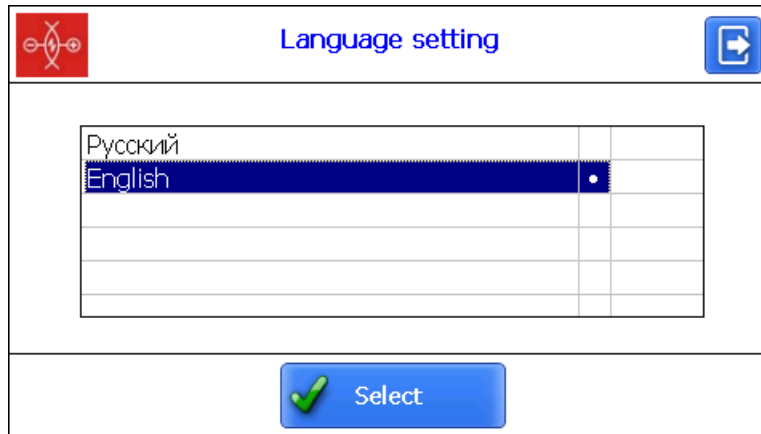

If no such file is available, it is necessary to use the new files preparation procedure, which is described in par. [19.2.4.1.](#), and then load a new language file from PC to PDA as it is shown in par. [20.1.2.](#)

## 11.6. Synchronization with PC

To transfer data between PDA and PC, it is necessary to synchronize them. There are two ways of synchronization via USB cable.

When you select **MS ActiveSync**, synchronization with PC is performed via the **ActiveSync** software (Windows XP), or via **Windows Mobile Device Center** (Windows 7).

When you select **Mass Storage**, the device is detected in Windows as an external storage device.

To select the type of synchronization, press the **Synchronization** button in the **Device** window. Next, select the required type and press **Save**.

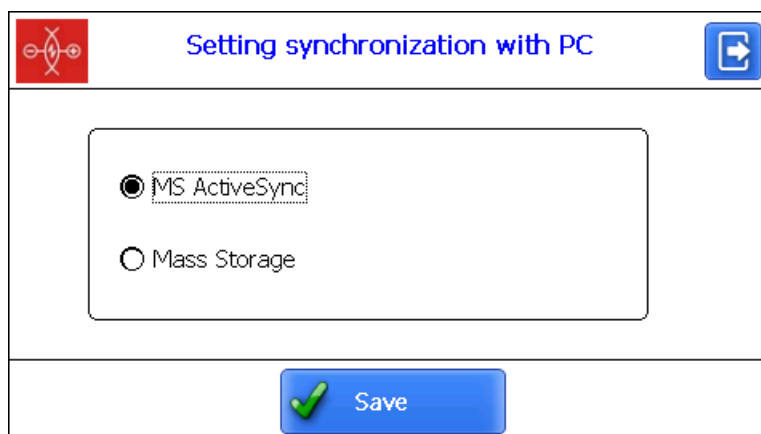

To apply the changes, PDA will prompt you to restart. If you do not need to sync the PDA with PC currently, you can restart the PDA later.

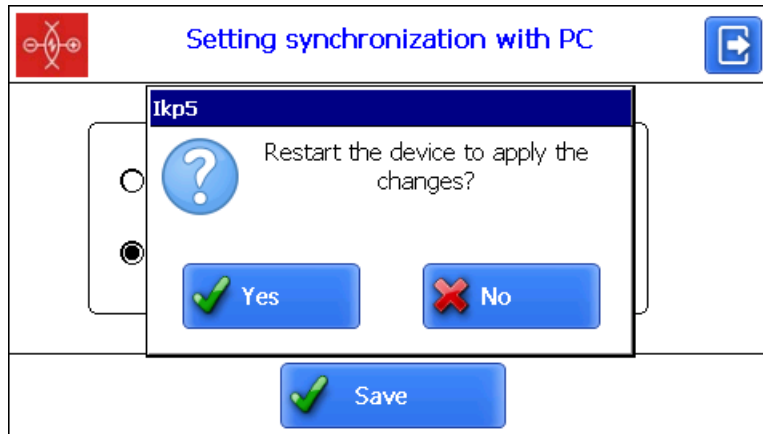

## 12. Measurement parameters setting

The **Parameters** window:

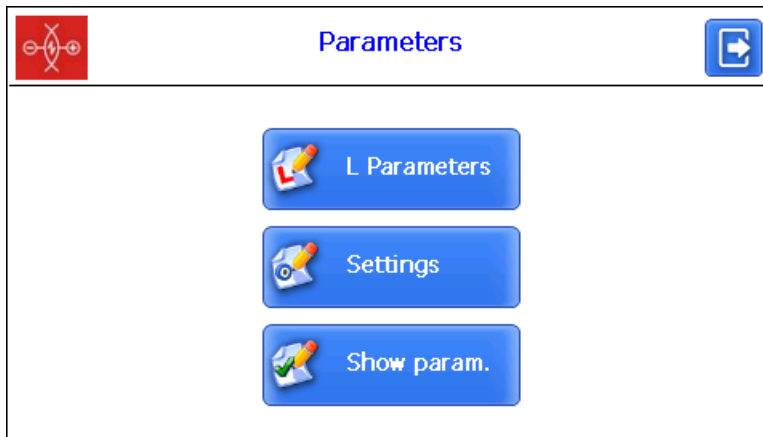

Button	Assignment
Settings	Calculation methods setting
Show param.	Selection of displayed parameters
L Parameters	L Parameters setting

### 12.1. Calculation methods setting

To select the calculation method, press the **Settings** button. The following window will appear:

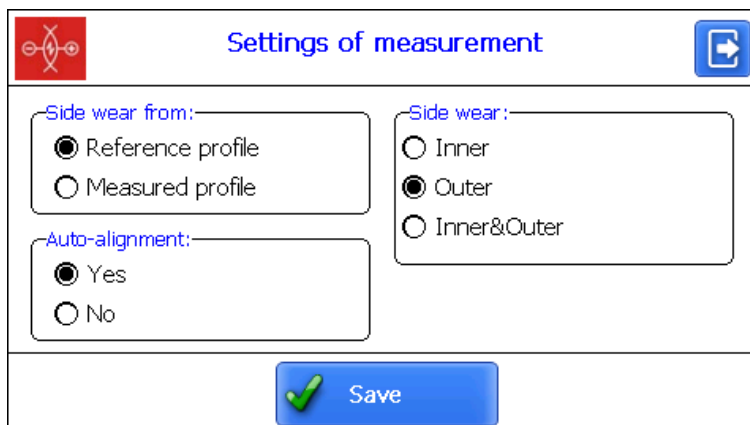



**Side wear from:**

**Reference profile**

The wear is measured at the height L1 from the rolling surface of the reference head.

**Measured profile**

The wear is measured at the height L1 from the rolling surface of the measured rail head.

**Side wear:**

**Inner**

The side wear is measured from the inside of the rail.

**Outer**

The side wear is measured from the outside of the rail.

**Inner&Outer**

The side wear is measured from the inside and outside of the rail. The result is the maximum wear.

**Auto-alignment:**

**Yes**

After the measurement, the profile will be aligned relative to the selected reference profile.



**No**

After the measurement, the alignment is not performed. The profile inclination angle and its parameters are calculated based on the device calibration.

After selecting the required parameters, press the **Save** button to save changes.

## 12.2. Selection of displayed parameters

To enter the mode, press the **Show param.** button.

Show parameters

Name	Show/Hide	
Vertical wear(Hv)	✓	
Side wear(Hh)	✓	
Reduced wear(Hr)	✓	
Side wear 45'(Hh45)	✓	
Reduced wear 45'(Hr45)	✓	
Rail width(W)		



To select/deselect the parameter to display, double-click in the **Show/Hide** column opposite to the required parameter. After selecting, you need to press **Save**.

### 12.3. L-parameters setting

To set L-parameters, press the **L Parameters** button.

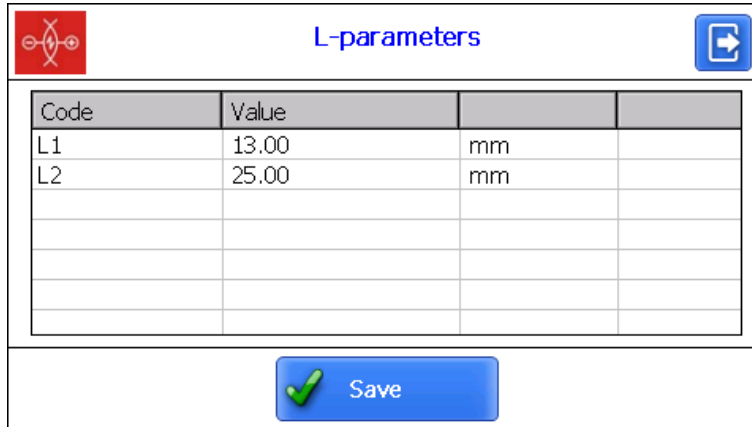

Code	Value		
L1	13.00	mm	
L2	25.00	mm	

To edit the parameters, double-click in the **Value** column opposite to the required parameter, and enter a new value in the **Data Input** window. Press the **Enter** button - .

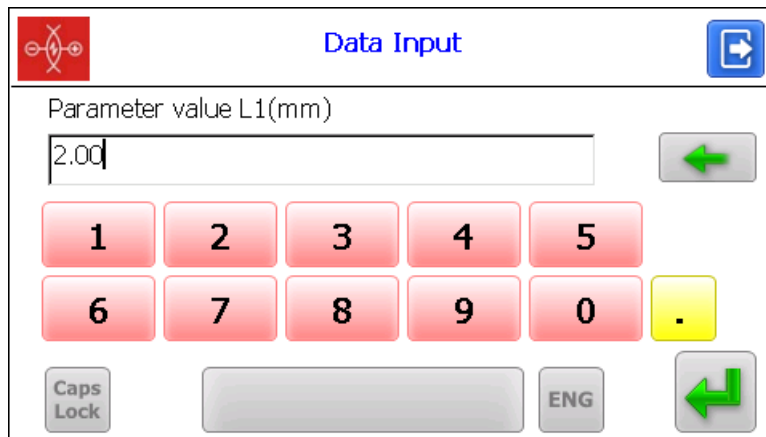

When you have set all parameters, press the **Save** button to save them.

## 13. Setting the database parameters, tolerances and references

The **Settings** window:

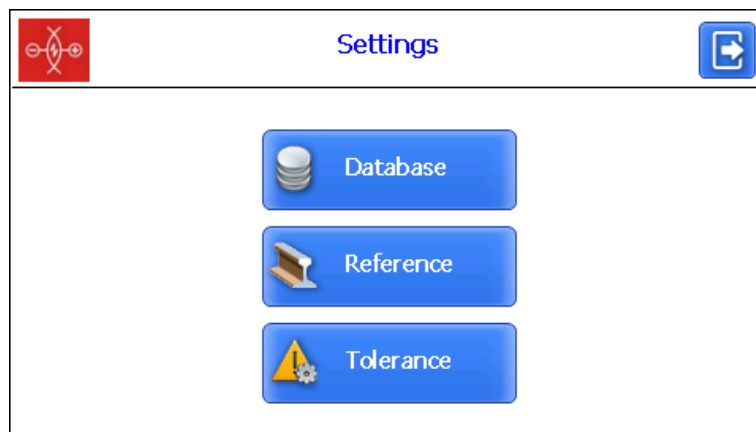

Button	Assignment
Database	Database selection
Reference	Reference profile selection
Tolerance	Setting of tolerances

### 13.1. Selection of the current database

You can save the measurement results to the PDA database, when it is necessary. The program makes it possible to create and to store several database files related to the date of measurement.

To select the database file, press the **Database** button.

19

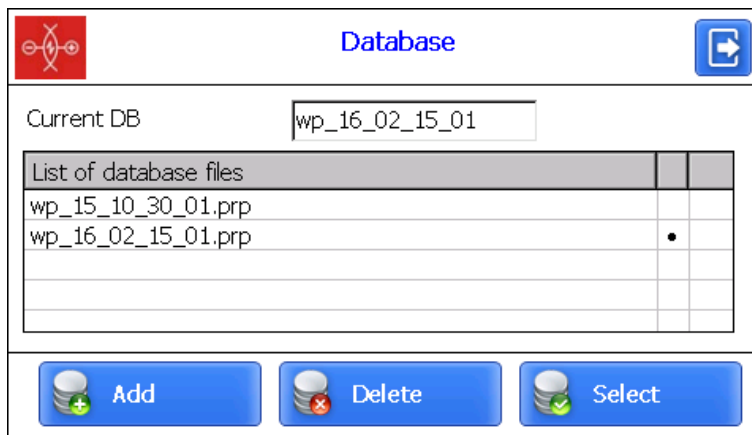

To create a new database, press the **Add** button. The window for entering a name of a new database will appear.

By default, it will be prompted to form the database file with the name **wp\_yy\_mm\_dd.ikp**, where yy\_mm\_dd is the current date:

**yy** – the last two digits of the year;

**mm** – month;

**dd** – day.

You can agree with this name, or enter another:

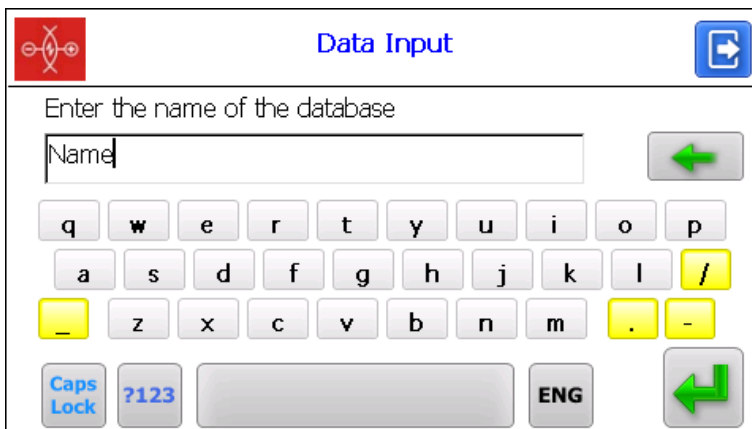

Press the **Enter** button - .

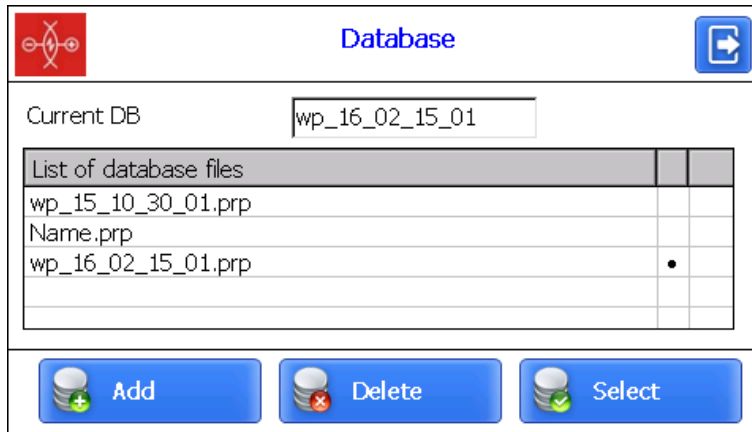

To select a database from a list, activate the line and press **Select**. The selected file will be marked with "•".

To delete the database file, activate the line and press **Delete**. If you delete the current database, the error message will appear.

### 13.2. Reference profile selection and installation

The program allows to compare the scanned profile of the rail with the reference profile. To select the reference profile, press the **Reference** button.

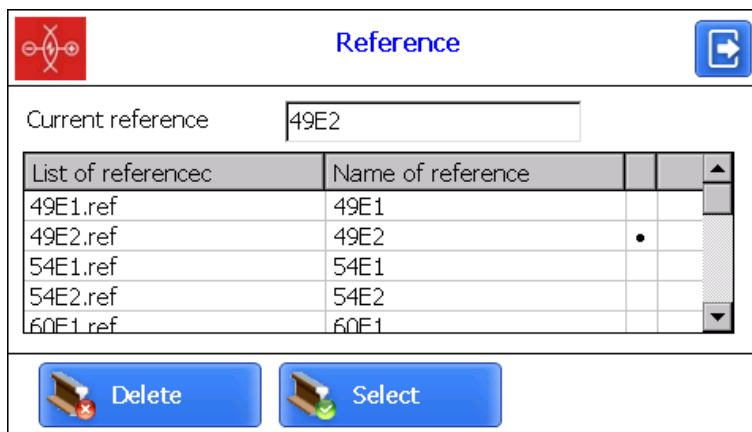

To select the reference file, activate the line and press **Select**. The selected file will be marked with "•".

To delete the reference file, activate the line and press **Delete**. If you delete the current reference, the error message will appear.

#### 13.2.1. Writing the reference profile to the database

Reference profiles are stored in the PDA database as profile description files with **.ref** extension. The PDA is supplied with several pre-installed profiles.

If there is no required reference profile in the database, the user can request the missing profile from **RIFTEK** (free service), and then transfer the received profile to the PDA.

### 13.3. Setting of tolerances

The program automatically controls measured geometric parameters for going out beyond the tolerances set. It is possible for the user to create groups of tolerances. Control of parameters will be performed for a selected group.

To select the current group of tolerances, press the **Tolerance** button.

The table will show tolerances only for the selected geometric parameters.

The red color indicates the maximum critical values of deviation from the reference parameters.

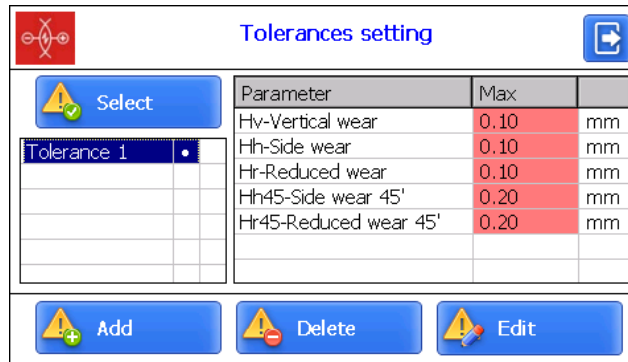

21

To select the group of tolerances, activate the line and press **Select**. The selected file will be marked with "\*".

To delete the tolerance, activate the line and press **Delete**. If you delete the current tolerance, the error message will appear.

To edit the tolerance, activate the line and press **Edit**.

To add a new tolerance, activate the line with the type name and press **Add**. You will see on the screen:

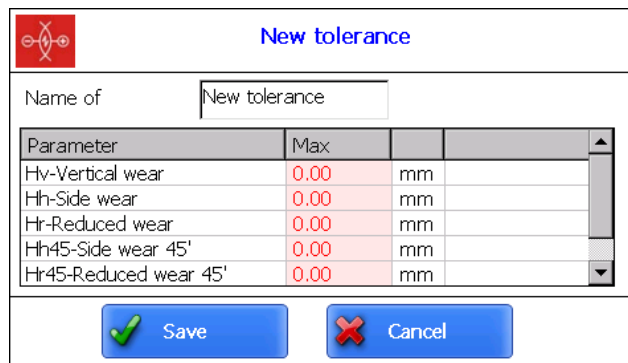

To change the type name, it is necessary to set cursor in the **Name of Tolerance** field, and to enter a new name in the appeared window. Then press the **Enter** button -

To edit the value, it is necessary to double-click on the **Max** column opposite to the specific parameter, and to enter a new value in the emerged window. Then press the **Enter** button. If any parameter has a zero value, the tolerance will not be used.

To save changes, press **Save**.

## 14. Updating of PDA software

You can view the software version in the main program window:

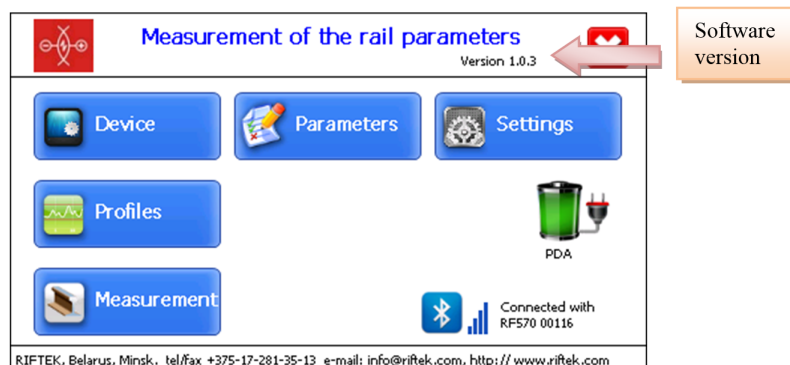

Procedure of PDA software updating is described in par. [20.1.5](#).

## 15. Shutdown

To shutdown the PDA, press the **Shutdown** button - .

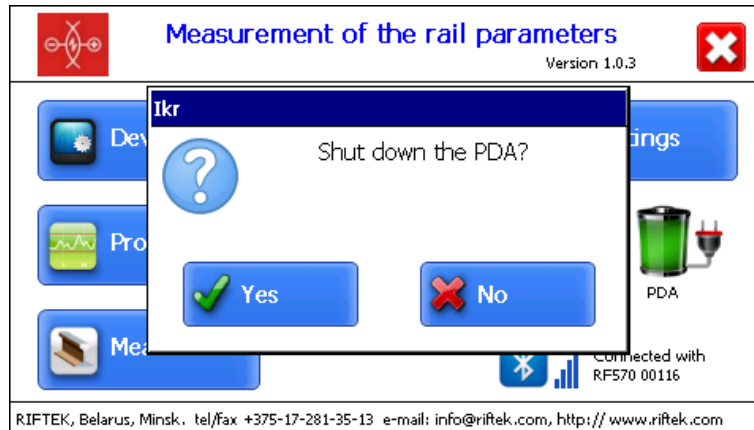

22

## 16. Measurements with database maintenance

There are two types of measurements:

1. Rapid measurements without saving the results.
2. Measurements with saving results to the database.

Procedure of rapid measurements is described in par. [10.2](#). How to select the measurement type, see par. [11.1](#).

When Bluetooth-connection is established, you can start to measure by pressing the **Measurement** button in the main program window. The window of rail parameters will appear on the screen:

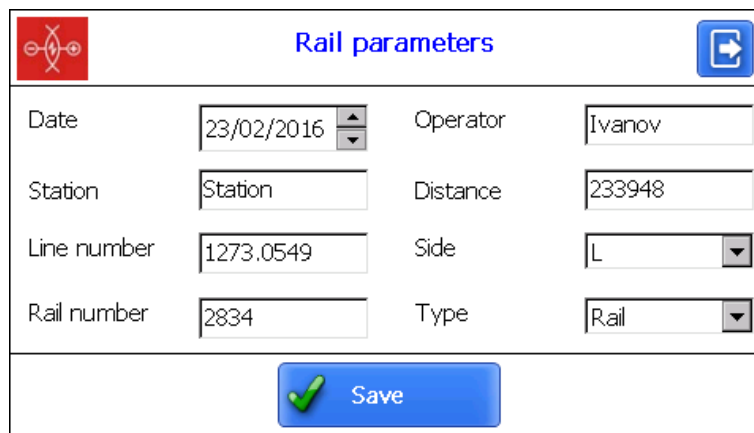

The screenshot shows the "Rail parameters" form. It contains several input fields and dropdown menus:

- Date: 23/02/2016
- Operator: Ivanov
- Station: Station
- Distance: 233948
- Line number: 1273.0549
- Side: L
- Rail number: 2834
- Type: Rail

A "Save" button with a green checkmark is located at the bottom of the form.

It is necessary to enter parameters and then to press **Save**. The PDA will show the measurement window:

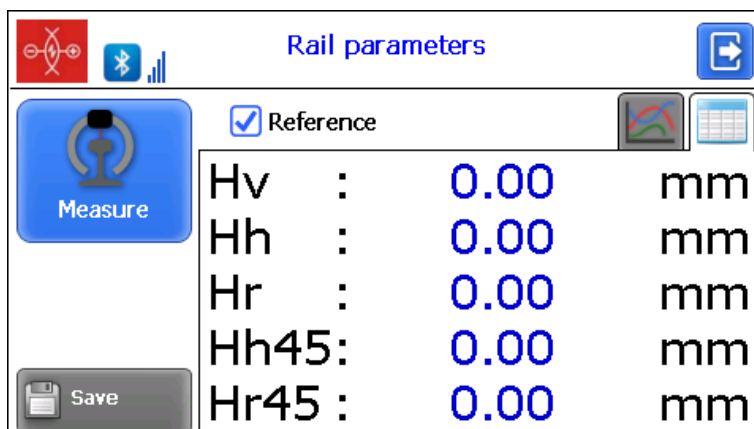

The screenshot shows the "Rail parameters" form with a "Reference" checkbox checked. The measurement results are displayed in a table:

Hv	:	0.00	mm
Hh	:	0.00	mm
Hr	:	0.00	mm
Hh45	:	0.00	mm
Hr45	:	0.00	mm

The form also includes a "Measure" button with a camera icon and a "Save" button with a floppy disk icon.

## 16.1. Measurement

Press the **Measure** button.

Upon completion of the scanning process, the PDA will show the values of selected geometrical parameters.

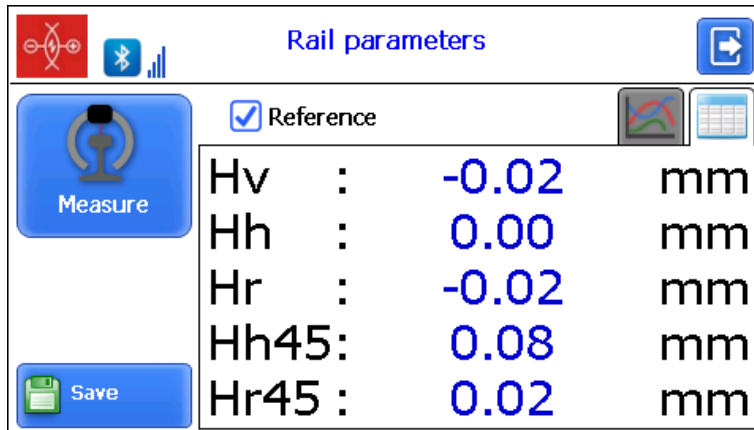

When the value is beyond the tolerances, it will be highlighted in red:

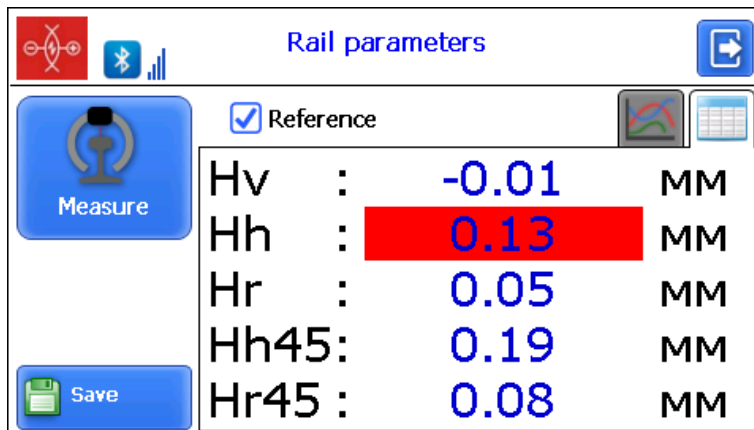

The program allows to display only parameters of the measured profile. To hide the reference values, you need to untick the **Reference** box.

To view the profile, press the **View** button - . The scanned profile and the selected reference profile will be displayed on the PDA screen.

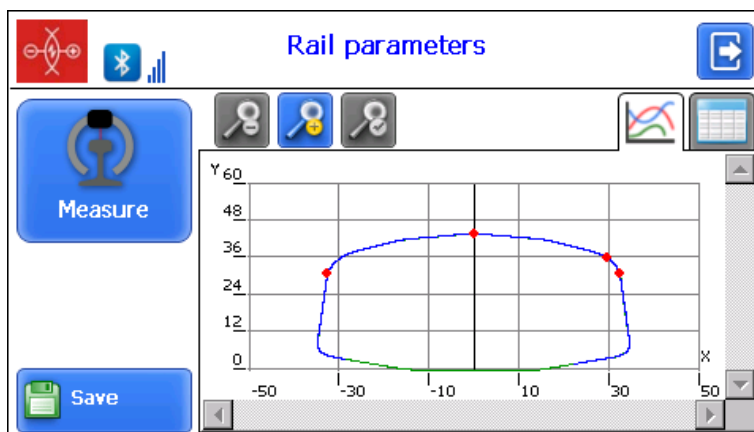

For more information, see par. [17.2](#).

To repeat the measurement, press the **Measure** button.

When a satisfactory result is obtained, press the **Save** button to save it.

When you measure the rail that was already measured, the program prompts you to replace the existing database file with the new one.

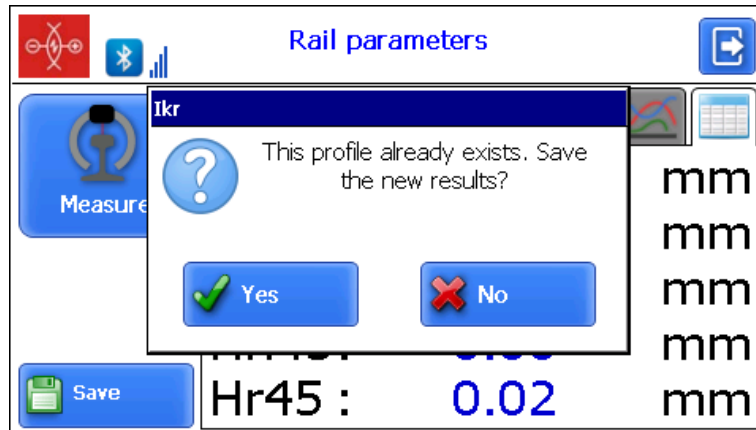



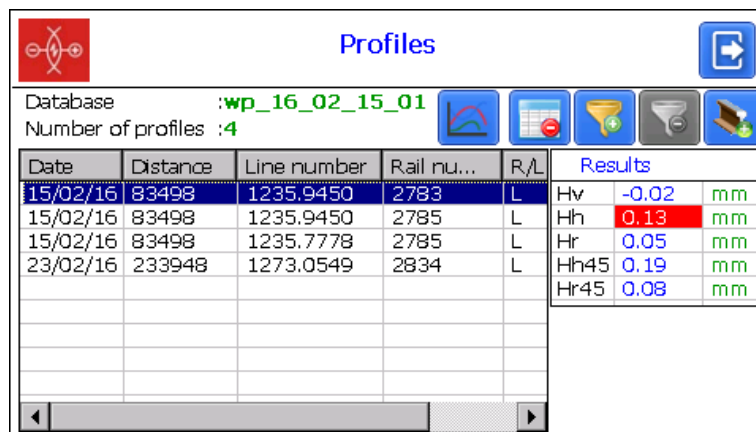

24

## 17. Browsing the database

To browse the saved data, press the **Profiles** button in the main window. The PDA screen will display information about the current database, quantity of saved profiles, table with saved profiles, and measured values of selected parameters.



### Buttons:

	Browse the profile of selected wheel
	Delete the selected wheel
	Add a filter
	Delete a filter
	Save the reference file

### 17.1. Data filtering

To apply filtering, press the **Filter** button and select the fields by which the data will be filtered.

An example of filtering by the **Line number** parameter is given below.



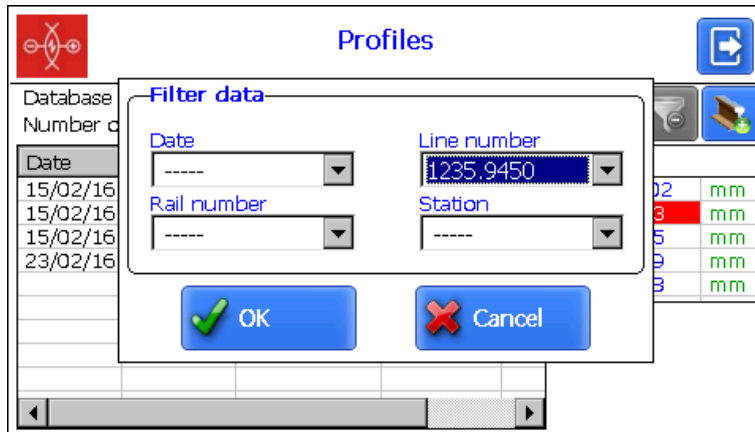

The filtered field will be highlighted in yellow:

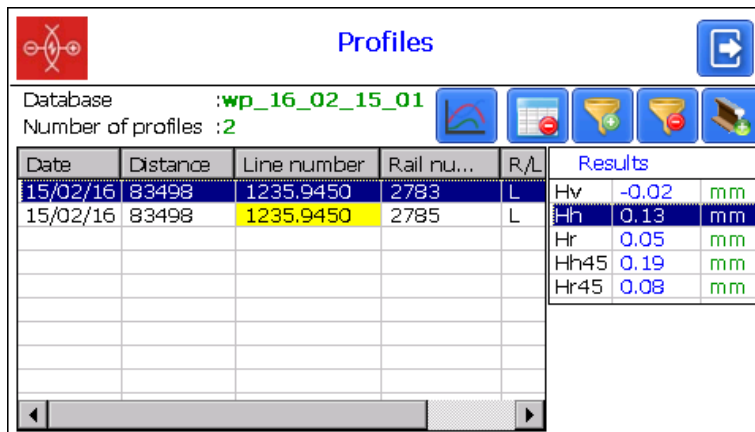

To delete the current filter, you need to press

## 17.2. Visualization of the rail profile

To browse the rail profile, you need to press the **Profile** button - . The scanned rail profile and the profile of selected reference will be displayed on the PDA screen.

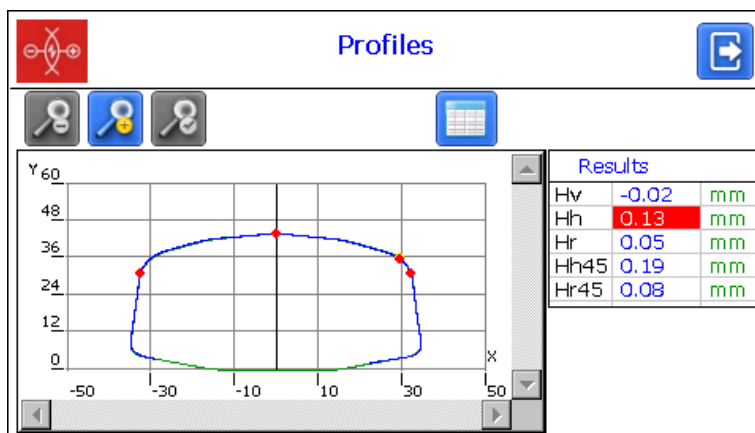

### Buttons:

	Zoom in
	Zoom out
	Standard image scale

An example of a zoomed image:

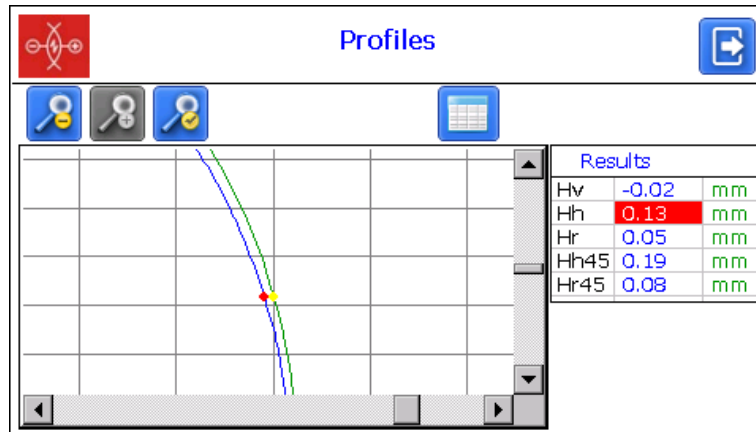

## 18. Installation of software on PC and startup

### 18.1. Installation of database support software

The **PRP\_DB** software is intended for maintaining the rail wear database on a personal computer.

To install the software, insert a compact disk to PC CD drive, select and start **Install\_PRP.exe** file in the **Software** folder. Follow instructions of the installation wizard. By default, the program is installed in **C:\Program Files (x86)\Riftek, LLC\Prp\_DB\**.

### 18.2. Synchronization of PDA and PC

There are two ways of synchronization via USB cable to transfer data between PDA and PC:

- MS ActiveSync
- Mass Storage

When you select **MS ActiveSync**, synchronization with PC is performed via the **ActiveSync** software (Windows XP), or via **Windows Mobile Device Center** (Windows 7), which must be installed on PC. The installation files you can find on the supplied CD.

It is necessary to select **MS ActiveSync** as the synchronization type of PDA (see par. [11.6.](#)).

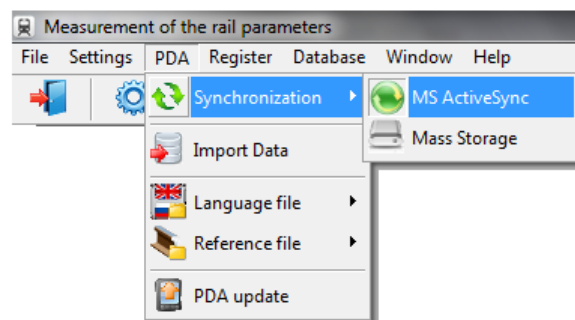

When you select **Mass Storage**, the device will be detected in Windows as an external storage device.

It is necessary to select **Mass Storage** as the synchronization type of PDA (see par. [11.6.](#)).

To check if the **MS ActiveSync** synchronization is correct, switch on the PDA and connect it to the USB port of the PC by the supplied cable. If the connection is successful, the message will appear on the screen:

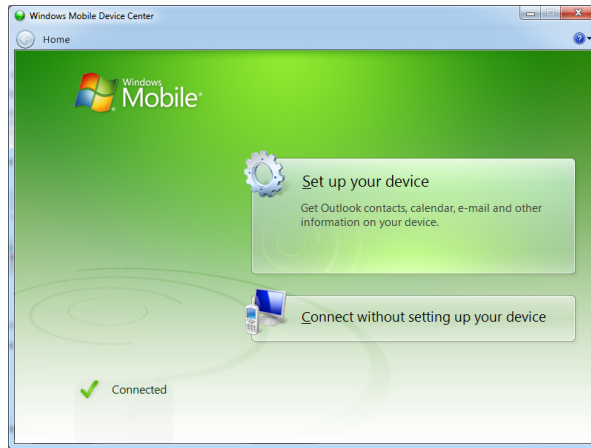

### 18.3. Program startup

To start the program, click **Start > All programs > Riftek, LLC > PRP\_DB > Prp\_db.exe**. View of the main program window is shown below.

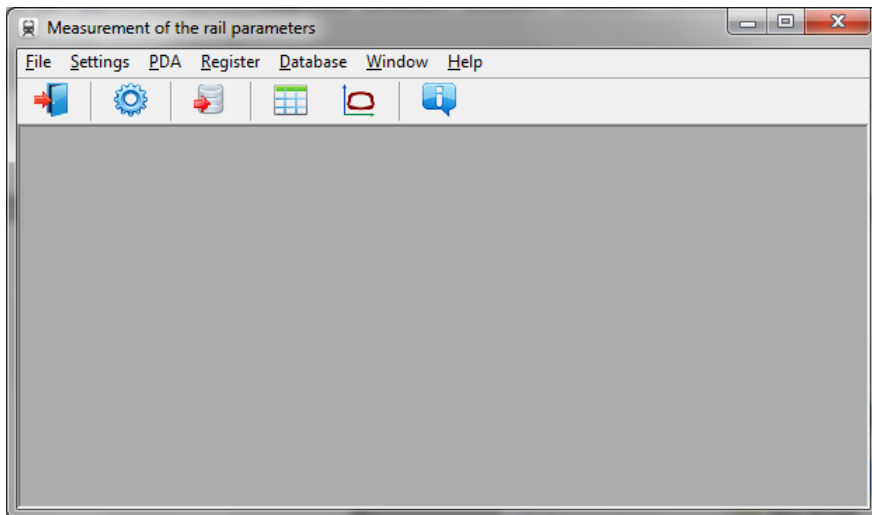

## 19. User settings of the program

### 19.1. Parameters setting

Select **Settings > Parameters** in the main window, or click .

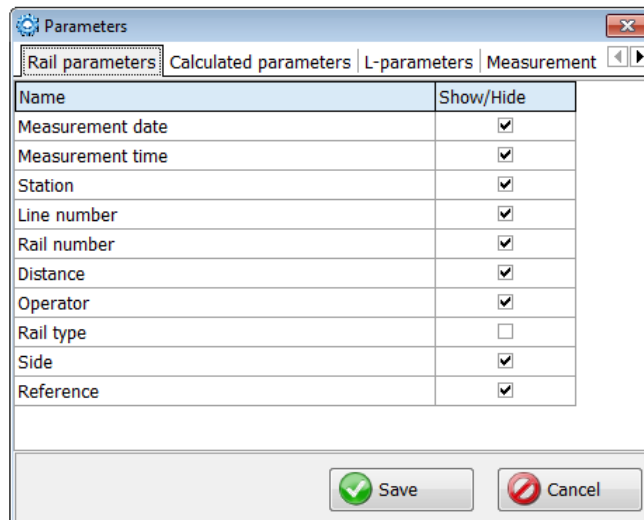

The **Parameters** window contains four tabs:

- Rail parameters
- Calculated parameters
- L-parameters
- Measurement method

### 19.1.1. "Rail parameters" tab

In this tab, you can select parameters, which will be displayed on the screen when browsing the database.

Rail parameters   Calculated parameters   L-parameters   Measurement	
Name	Show/Hide
Measurement date	<input checked="" type="checkbox"/>
Measurement time	<input checked="" type="checkbox"/>
Station	<input checked="" type="checkbox"/>
Line number	<input checked="" type="checkbox"/>
Rail number	<input checked="" type="checkbox"/>
Distance	<input checked="" type="checkbox"/>
Operator	<input checked="" type="checkbox"/>
Rail type	<input type="checkbox"/>
Side	<input checked="" type="checkbox"/>
Reference	<input checked="" type="checkbox"/>

If the parameter is selected, its value will be shown in the table of results and in the table of profiles.

### 19.1.2. "Calculated parameters" tab

In this tab, you can select the geometrical parameters, which will be calculated and displayed on the screen when browsing the database.

Rail parameters   Calculated parameters   L-parameters   Measurement	
Name	Show/Hide
Vertical wear (Hv)	<input checked="" type="checkbox"/>
Side wear (Hh)	<input checked="" type="checkbox"/>
Reduced wear (Hr)	<input checked="" type="checkbox"/>
Side wear 45' (Hh45)	<input checked="" type="checkbox"/>
Reduced wear 45' (Hr45)	<input checked="" type="checkbox"/>
Rail width (W)	<input checked="" type="checkbox"/>

The description and functions of parameters see in par. [9.2](#).

### 19.1.3. "L-parameters" tab

In this tab, you can set the values of L-parameters.

Rail parameters   Calculated parameters   L-parameters   Meas		
Code	Value	
Parameter L1	13,00	mm
Parameter L2	20,00	mm

The description and functions of L-parameters see in par. [9.1](#).

### 19.1.4. "Measurement method" tab

In this tab, you can select the measurement method.

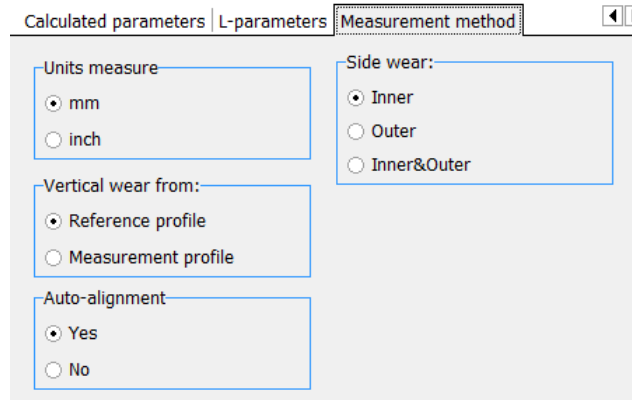

The description and functions of measurement methods see in par. [12.1](#).

#### 19.1.4.1. Selection of measurement units

All parameters and measurement results can be in the Metric system (millimeters), or in the English system (inches).

To set the units of measurement, you need to select **mm** or **inches** in the **Units of measurement** field. After saving the changes, all information will be displayed in the selected units of measurement.

### 19.2. Database settings

#### 19.2.1. Setting the path to database

It is possible for the user to change the drive and the directory of the profiles database storage. In the main window, select **File > Path to DB...**

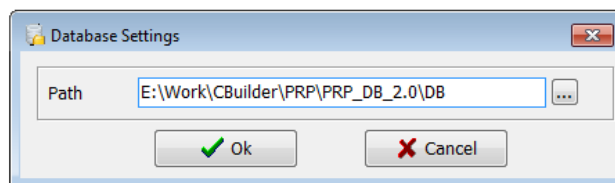

Next:

- click **Ok**
- specify a new path to the database
- confirm the creation of a new database

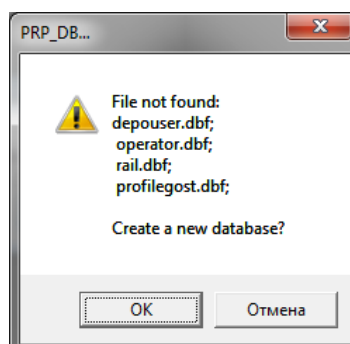

All database files will be copied to the specified path.

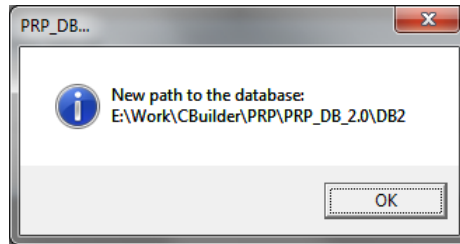

### 19.2.2. Creation of empty database

To create an empty database, select **File > New DB**.

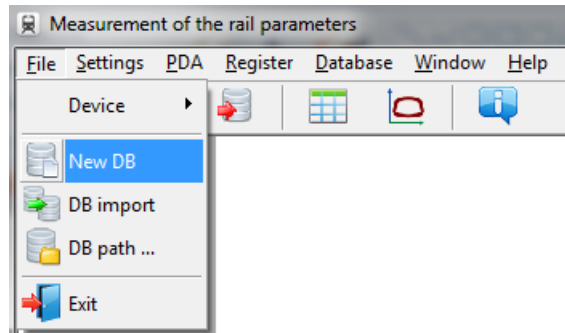

30

All data except the reference files will be deleted from the database. At the same time, the **DB(dd.mm.yy)** directory will be created in the installation directory whereto all the deleted data will be copied (**dd.mm.yy** – current date). If necessary, these data can be restored.

### 19.2.3. Import of database

To import data to the database from the other database, you need to:

- Select **File > Import Data**.
- Select the directory with DB files in the left window. All files will appear in the right window:

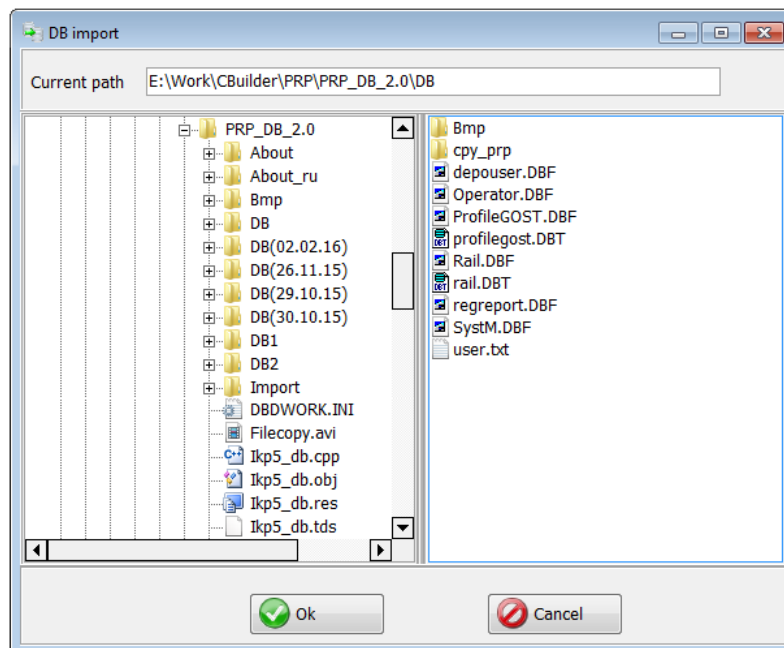

- Click **OK** to import data.

### 19.2.4. Language selection

To change the language, select **Settings > Language** and select the required language support file.

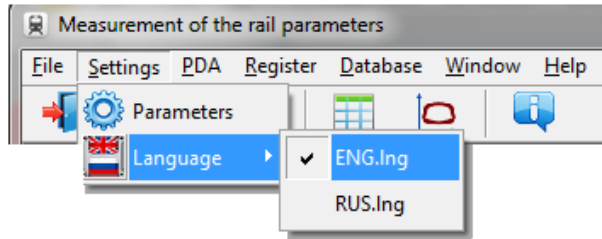

#### 19.2.4.1. Preparation and installation of the language support file

The user can change the language, form his own language support files as well as change/edit the terminology used. Language support files are located in the directory used in the process of installation. By default, the following directory is used: **C:\Program Files (x86)\Riftek, LLC\lcp5\_db\Language\**.

The directory contains two files, **RUS.Ing** and **ENG.Ing**, to support Russian and English languages respectively.

To create the support file for any other language, it is necessary to:

- copy one of the existing files, for example - **ENG.Ing**, under the other name, for example - **DEU.Ing**;
- edit the renamed file by using any text processor, namely, change all terms and phrases to analogous ones from the required language;
- save the edited **\*.Ing** file in the **Language** directory.

To edit the terminology, it is necessary to:

- edit the corresponding language file by using any text processor;
- save the edited **\*.Ing** file in the **Language** directory.



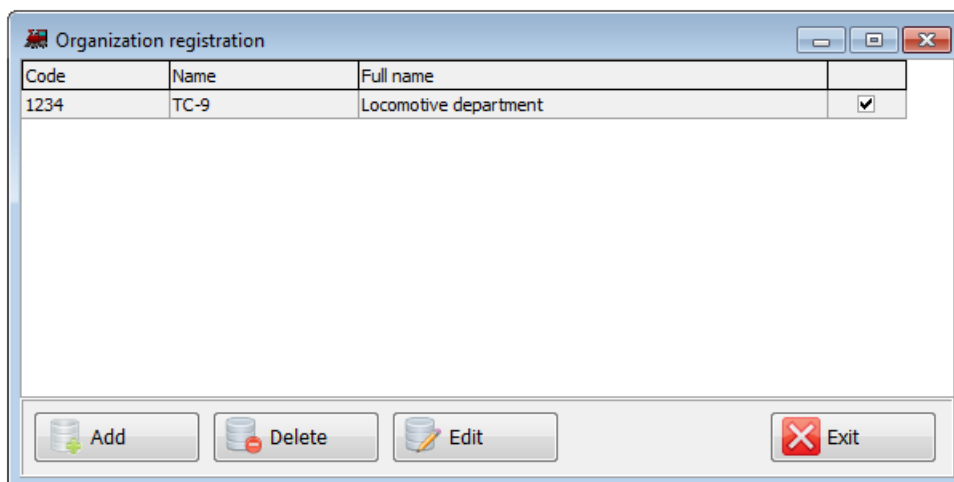

### 19.3. Registration data

#### 19.3.1. Registration of organizations

To add/chose the user organization, select **Registration > Organization**. Subsequently, this information will be used in automatic generation of reports.



### Buttons:

 Add	Add a new organization
 Delete	Delete the selected organization
 Edit	Edit the selected organization
 Exit	Exit the mode

To select a current organization:

- Click **Edit**
- Tick the depot
- Click **Save**

**Organization**

Code

Name

Full name

### 19.3.2. Registration of operators

Steps to follow: **Registration > Operator**. Operators data are used for identifying operators by **Number**.

**Operator registration**

Number	Name
1111	Ivanov
2222	Petrov

Functions of buttons are similar to those in par. [19.3.1](#).

### 19.3.3. Registration of reference profiles

The program comes with several preset profiles. In addition, the user can form a description of the required profile himself or request it from **RIFTEK** (free service).



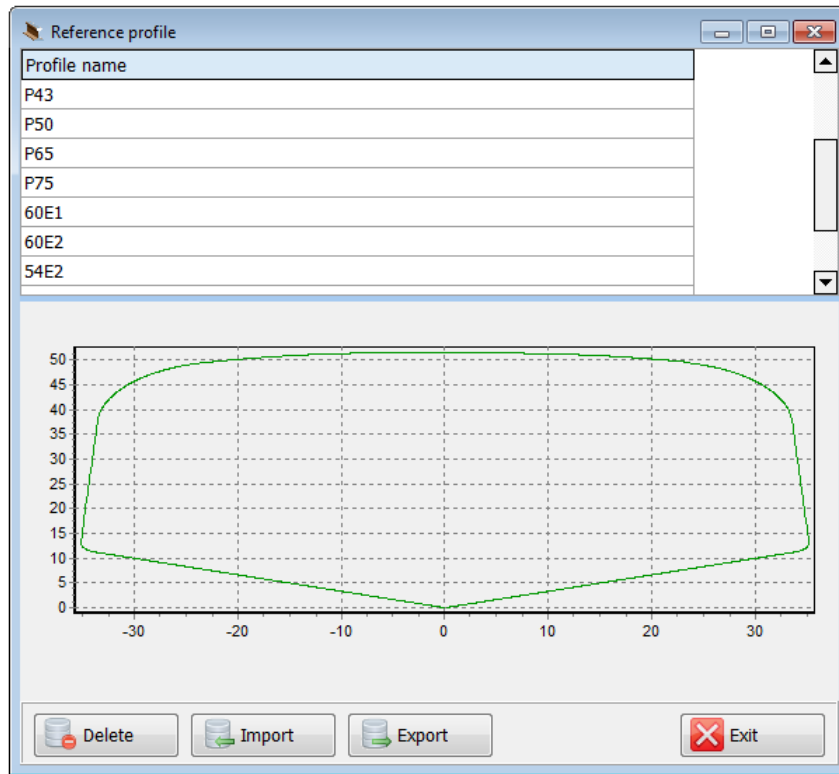

To browse available profiles, select **Registration > Reference**:





The window of profiles displays the table with the list of reference profiles saved to database, and a graphical view of selected profile.

**Buttons:**

 Delete	Delete the reference profile
 Import	Import the reference profile from *.ref file
 Export	Export the reference profile to *.ref file
 Exit	Exit the mode

**19.3.3.1. Request and registration of the profile file**

To get .ref file of reference profile send the drawing of profile to **RIFTEK** ([info@riftek.com](mailto:info@riftek.com)). Register the received .ref file as follows:

- click **Import**
- in the window appeared indicate the way to the .ref-file
- click **Open**

The profile will be added to the base of reference profiles.

## 20. Data exchange between PDA and PC

To exchange data between PC and PDA, you need to select the device: **File > Device > RF303M-PDA**.

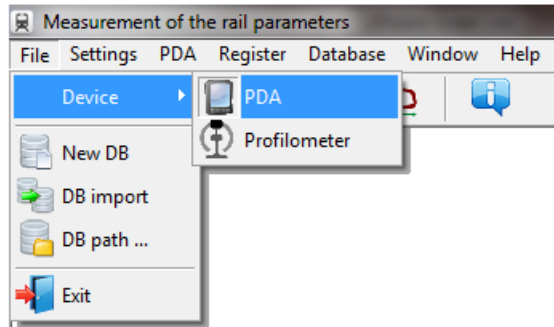

Data exchange between PC and PDA is performed by means of direct cable connection of PDA to PC USB-port (special **RF505.42** cable is supplied).

There are two ways of synchronization via USB cable:

- ActiveSync
- Mass Storage

For more details, see par. [11.6](#).

### 20.1. ActiveSync synchronization

When you select this type of synchronization, additional features of data exchange with PDA will be available:

- Transfer of database files to PC
- Transfer of language files
- Transfer of reference profile files
- PDA software update

#### 20.1.1. Transfer of database file to PC

To transfer the database file from PDA to PC, it is necessary to:

- select **PDA > Import Data**

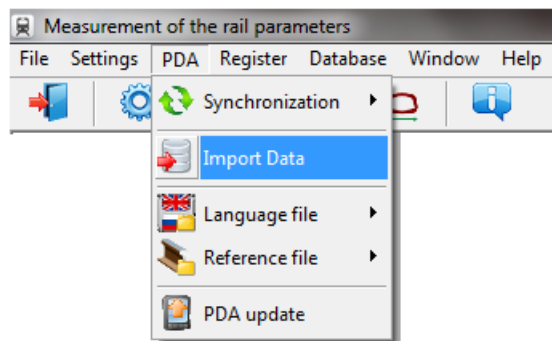

- mark the required files in the emerged window and click **OK**



Double-click on the selected file in order to see information about saved data.

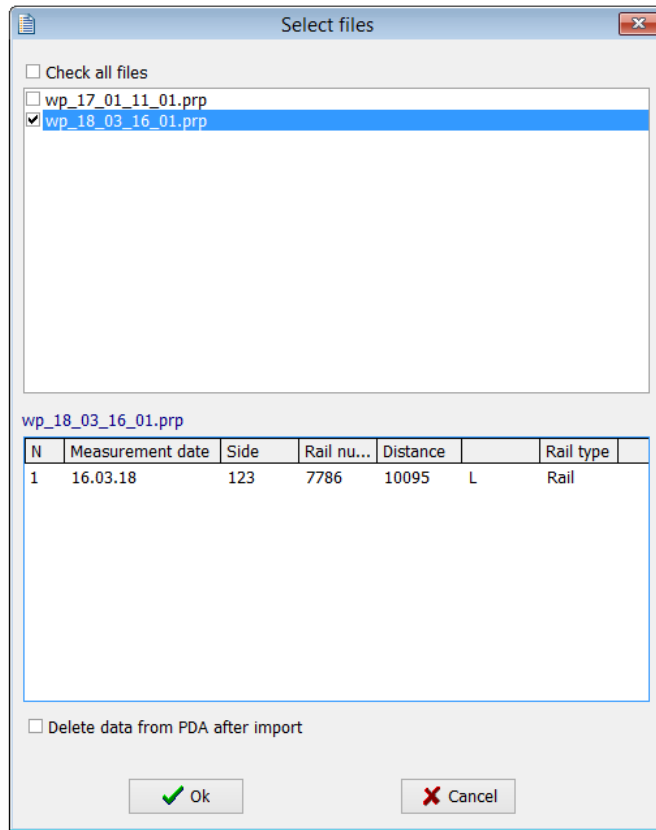

### 20.1.2. Transfer of language file from PC to PDA

To transfer the language file from PC to PDA, it is necessary to:

- select **PDA > Language file > Export**

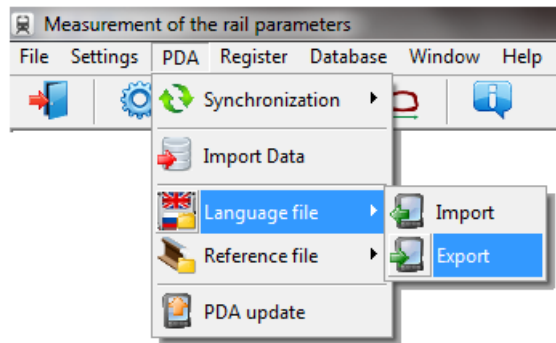

- select the required file

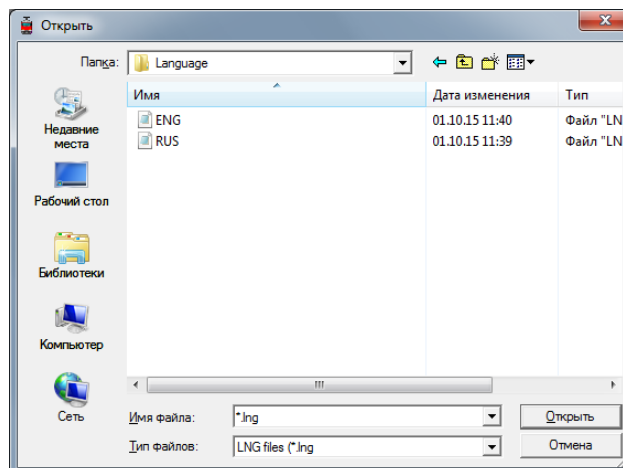

If transfer is successful, the screen will show:

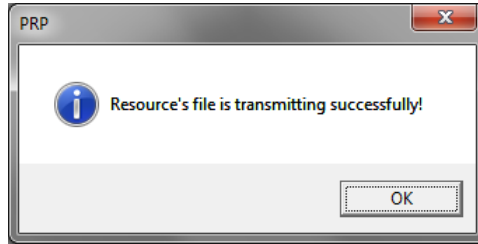

### 20.1.3. Transfer of language file from PDA to PC

To transfer the language file from PDA to PC, it is necessary to:

- select **PDA > Language file > Import**

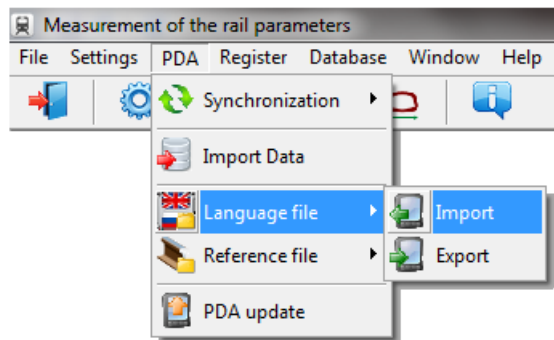

- select the required file

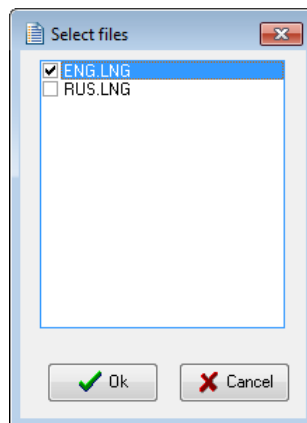

If transfer is successful, the selected files will be saved to the specified path.

### 20.1.4. Transfer of reference profile files from PC to PDA

To transfer the reference profile file from PC to PDA, it is necessary to:

- select **PDA > Reference file > Export**

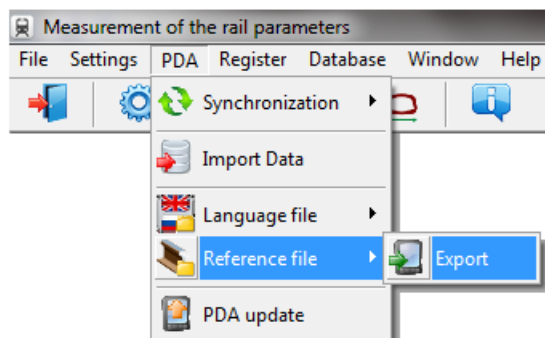

- select the required **.ref** file  
If transfer is successful, the screen will show:

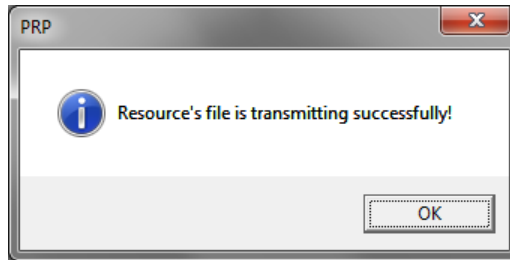

### 20.1.5. Updating of PDA software

The latest software version can be downloaded from the RIFTEK's website. To transfer the update file to PDA, it is necessary to:

- select **PDA > PDA update**

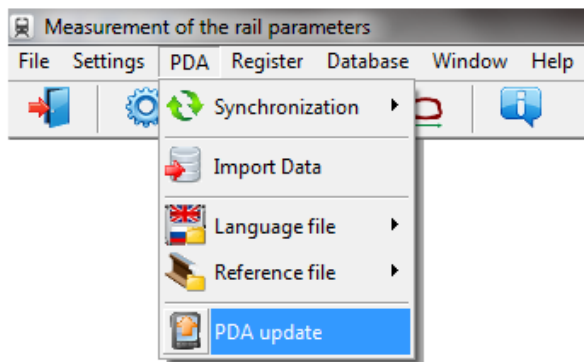

- select a file for transfer  
If transfer is successful, the following window will appear:

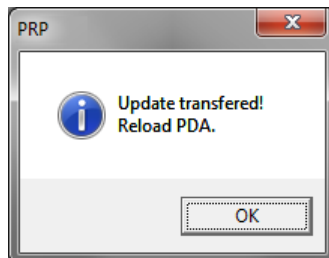

## 20.2. Mass Storage synchronization

When you select this type of synchronization, PDA is detected as an external storage device. Therefore, the only **Import Data** item is active. Transfer of language/reference files from PDA to PC and back can be performed by simple copying.

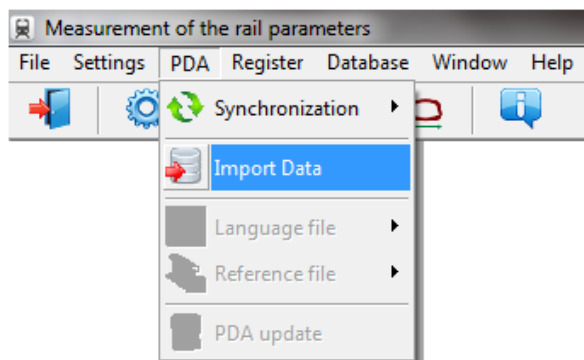

To transfer database files from PDA to PC, it is necessary to:

- select **PDA > Import Data**
- specify the path to the database on PDA (by default, **C:\Program Files (x86)\Riftek, LLC\Prp\_db\**)

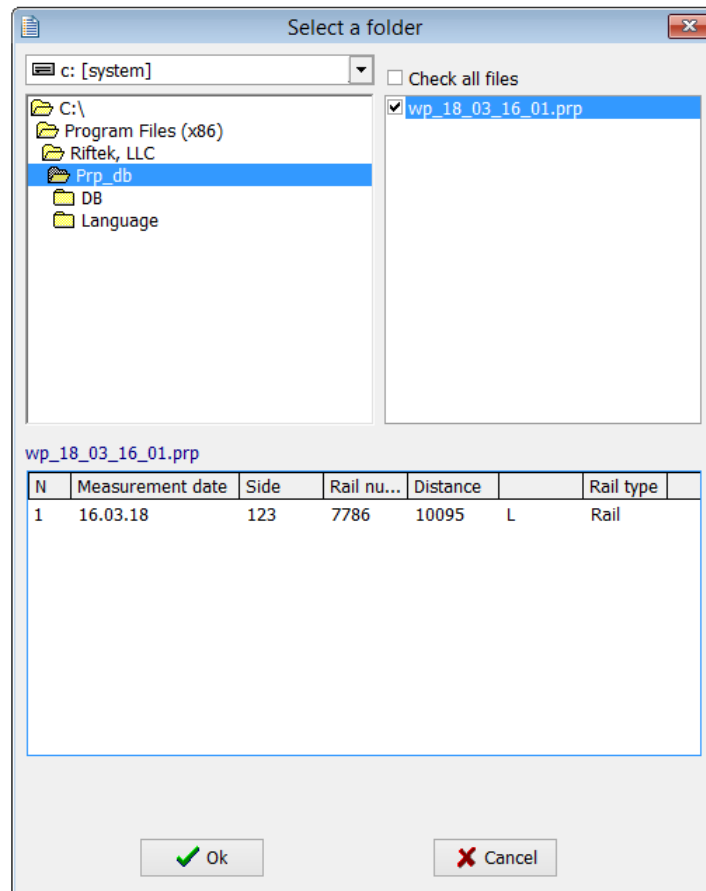

- mark the required files in the emerged window and click **OK**



Double-click on the selected file in order to see information about saved data.

# 21. Working with profilograms and wear calculations

## 21.1. Browsing the graph and profile coordinates

To browse the saved profiles, select **Database > Profiles**, or click the **Profiles** button - .



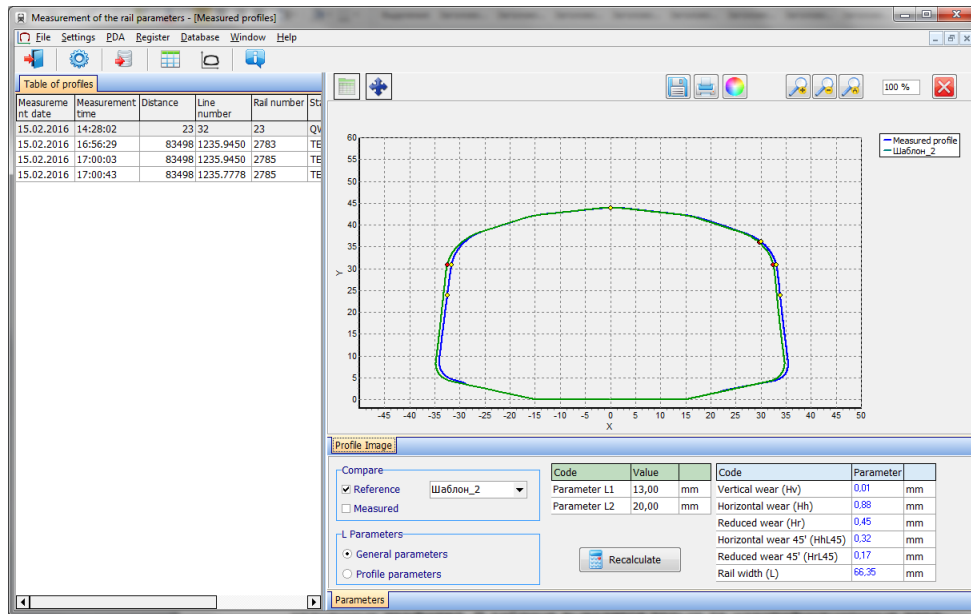



39



At the left side of the window you can see the **Table of profiles** tab, which contains a list of saved profiles. The table displays only those identification parameters that were selected in the parameters window (see par. [19.1](#)).

When selecting a profile, it is possible to browse a graphical image and geometric parameters of the measured rail. To browse the coordinates of the selected profile, you need to click the **Profile Values** button. After that, an additional tab will appear.

**Buttons:**

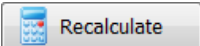
	Show/hide the <b>Profile Values</b> tab
	Show/hide the <b>Profile alignment</b> tab
	Save the profile image to file (.bmp file)
	Print the profile image
	Change the background color of the graph
	Zoom in/out the profile graph
	Calculate geometric parameters

## 21.2. "Parameters" tab

Calculated geometric parameters of the profile as well as L-parameters values are displayed on the **Parameters** tab, which is at the bottom of the window.

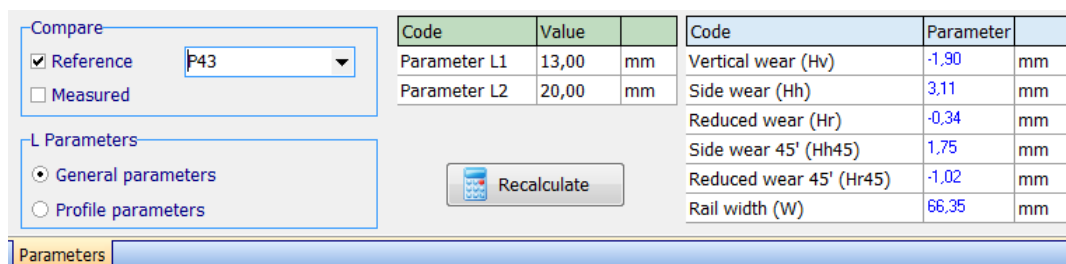

Code	Value	
Parameter L1	13,00	mm
Parameter L2	20,00	mm

Code	Parameter	
Vertical wear (Hv)	-1.90	mm
Side wear (Hh)	3.11	mm
Reduced wear (Hr)	-0.34	mm
Side wear 45' (Hh45)	1.75	mm
Reduced wear 45' (Hr45)	-1.02	mm
Rail width (W)	66.35	mm

40

### 21.2.1. Selecting a profile to compare

There are two ways to compare:

- with the reference profile,
- with the measured profile.

To compare the measured profile with the reference one, it is necessary to tick the **Reference** box.

When comparing with the reference profile, select the required reference profile in the drop-down list.

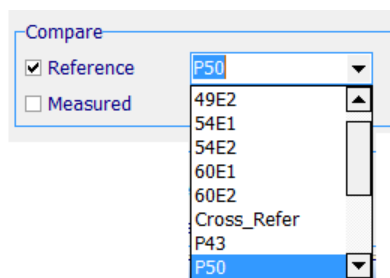

To compare two measured profiles, it is necessary to tick the **Measured** box. The **Table of profiles** tab will show an additional table for selecting a profile to compare.

### 21.2.2. Selecting L-parameters values

When calculating the geometric parameters, the specified support points are used (see par. [12.3](#)). There are two variants of L-parameters:

- General parameters
- Profile parameters

When selecting **General parameters**, values of L-parameters will be taken from the default parameters file (see par. [19.1.3](#)).

When selecting **Profile parameters**, values of L-parameters will be taken from the profile file, i.e. the values, which were set in PDA when measuring the rail (see par. [12.3](#)).

Values of L-parameters are displayed on the screen in the table of parameters.

Code	Value	
Parameter L1	13,00	mm
Parameter L2	20,00	mm

If necessary, it is possible to edit any value and to recalculate values of geometric parameters of the flange. To do it, click **Calculate**. Parameters of the measured profile and selected reference will be recalculated.



### 21.2.3. Geometric parameters of the profile

The table of calculated geometric parameters displays only those parameters, which were selected in the parameters window (see par. 19.1.2).

Code	Parameter	
Vertical wear (Hv)	-1.90	mm
Side wear (Hh)	3.11	mm
Reduced wear (Hr)	-0.34	mm
Side wear 45° (Hh45)	1.75	mm
Reduced wear 45° (Hr45)	-1.02	mm
Rail width (W)	66.35	mm

## 21.3. Wear calculation

### 21.3.1. Fast wear calculation

To obtain fast calculation of the profile wear at a certain point relative to the reference, put cursor bar to any of the profiles, and when a cross-like (+) mouse cursor appears press the left mouse key. The resulting screen will show the value of the coordinate difference between profiles taken along X- and Y-axes, as shown by arrows:

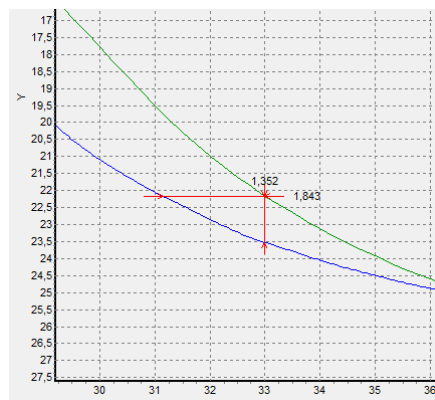

To remove size indication from the screen, it is necessary to put cursor to any of the profiles and press the right mouse key.

## 21.4. Browsing and saving a profile

To browse the table of values, it is necessary to select **Profile Values > Wear**. The table will show deviations of the selected profile from the reference profile in two directions (X and Y).

N	Values	Values
	on axis X	on axis Y
1	-27,31	1,36
2	-27,36	1,39
3	-27,41	1,41
4	-27,45	1,44
5	-27,50	1,46
6	-27,59	1,48
7	-27,68	1,49
8	-27,77	1,50
9	-27,86	1,52

### 21.4.1. Export to Excel, DXF, REF

To export the table to the Excel or DXF format or to create the reference file (REF), it is necessary to right-click on the table. The pop-up menu will appear:

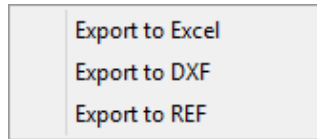

Select the needed menu item.

### 21.5. Alignment of profiles

To align the profiles relative to the reference profile, you need to click the **Alignment** button. The program will display an additional tab, where you can move the selected profile to the required position by using the arrows.

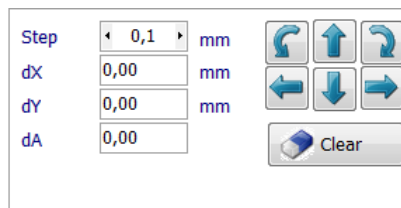

Next, specify the translation step and move the profile by using the **Up/Down, Left/Right** buttons.

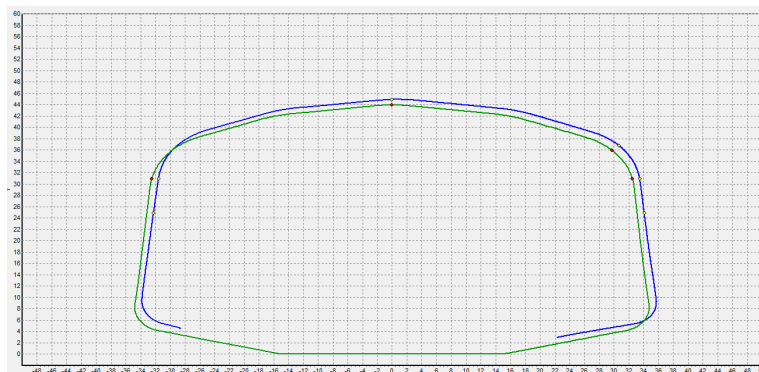

To save the changed profile, go to the tab of identification parameters of the profile and click **Save**.

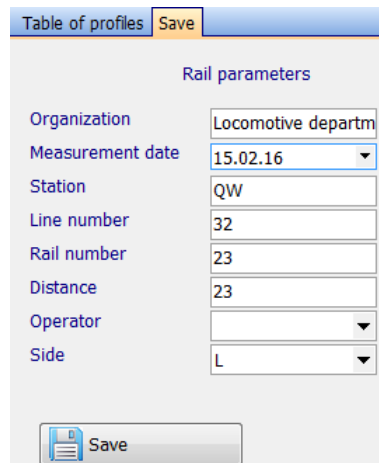



To create a new profile, it is necessary to change the identification parameters of the profile.

## 21.6. Superposition of profiles

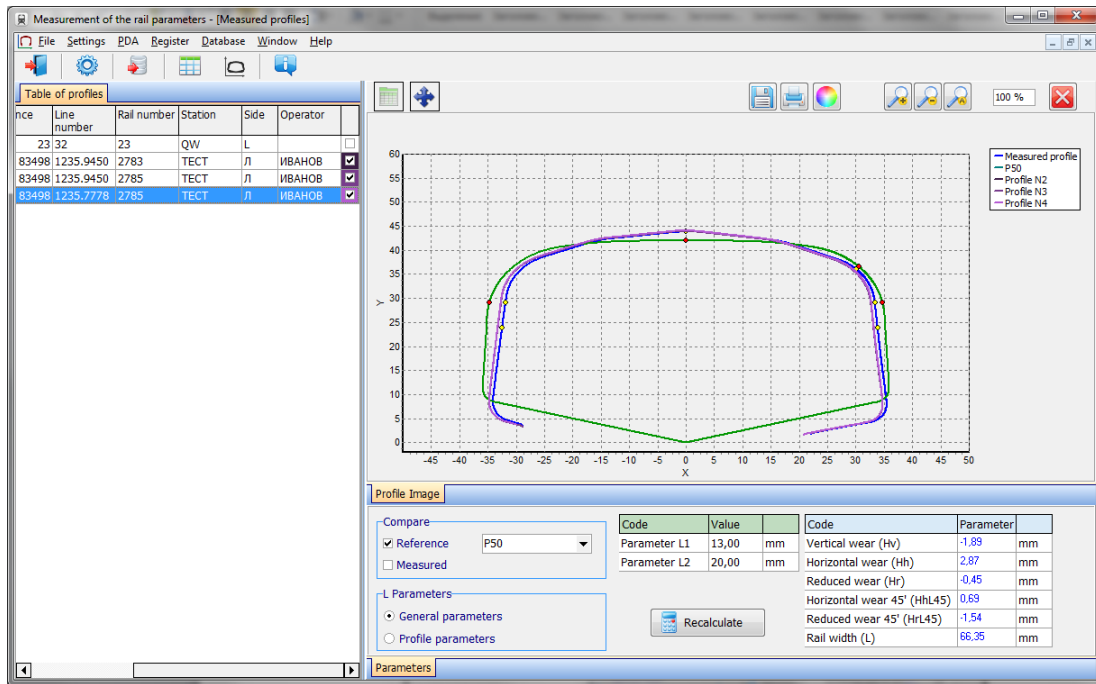
To superimpose several changed profiles, you need to tick the required profiles in the left table. Selected profiles will be displayed in different colors.



## 21.7. Rescaling

To change the image scale, mark a part of the image with the left mouse key, move the image by holding it with the right mouse key pressed, or with buttons **Increase** - , **Decrease** -  and **Show all** - .

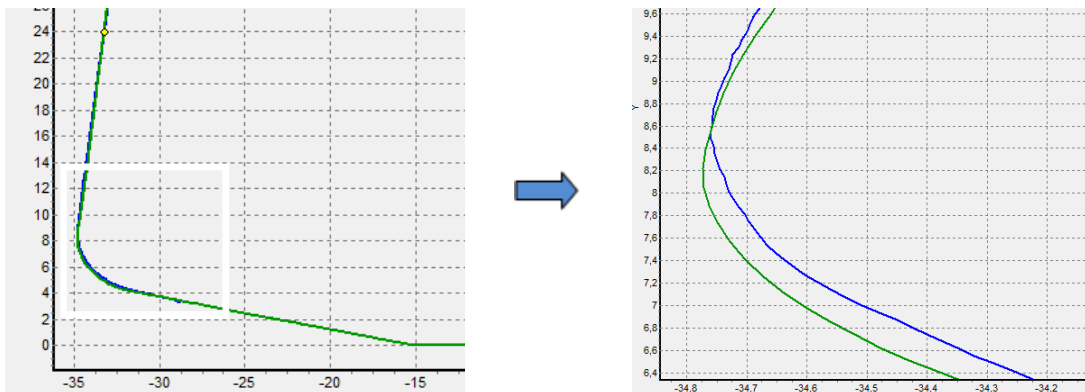

## 22. Scanning and editing of data

### 22.1. Scanning and filtering of data

Select **Database > Table** in the menu or click the **Table** button - . The form with results will be as follows:

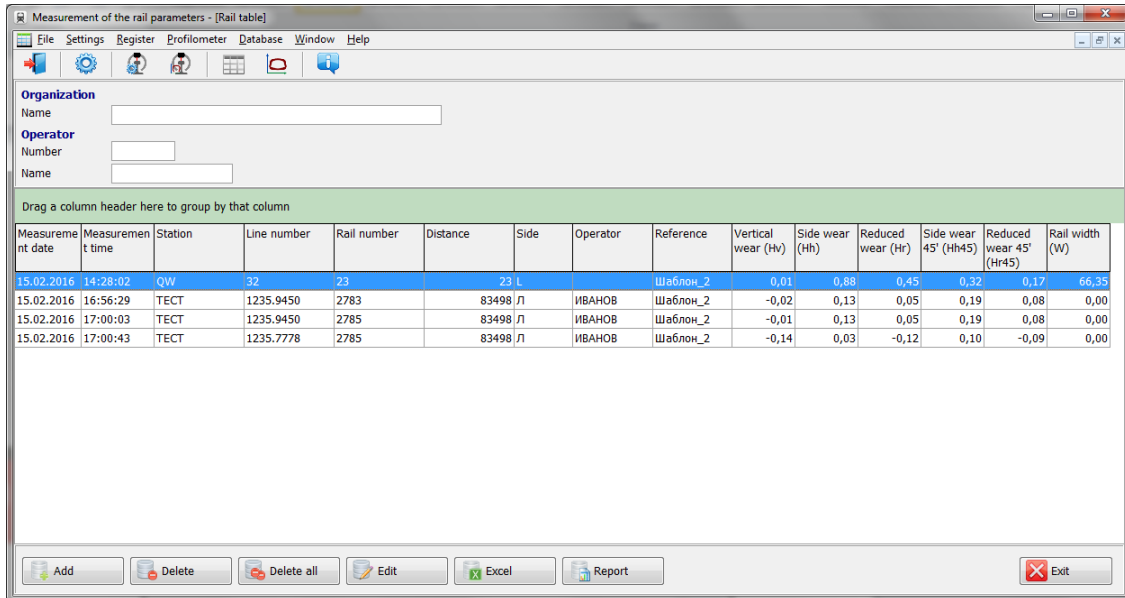

- **Hide/show the field**

The table displays the identification and geometric parameters of the rail, which are selected for displaying in the parameters settings (see par. [19.1.1](#) and [19.1.2](#)).

- **Data sorting**

To sort data for any of the fields, click the left mouse key on the header of the field column:

Measurement date	Measurement time	Line number
15.02.2016	14:28:02	32
15.02.2016	16:56:29	1235.9450
15.02.2016	17:00:03	1235.9450
15.02.2016	17:00:43	1235.7778

➔

Measurement date	Measurement time	Line number
15.02.2016	17:00:43	1235.7778
15.02.2016	16:56:29	1235.9450
15.02.2016	17:00:03	1235.9450
15.02.2016	14:28:02	32

To cancel data sorting, press the **Ctrl** key and click the left mouse key on the header of the field column.

- **Data filtering**

In order to filter data in any of the fields, click the left mouse key on the header of the field grouping, and select the required value in the emerged drop-down list:

Measurement date	Measurement time	Line number
15.02.2016	17:00:43	(All)
15.02.2016	16:56:29	(Custom...)
15.02.2016	17:00:03	<input type="checkbox"/> 1235.7778
15.02.2016	17:00:03	<input type="checkbox"/> 1235.9450
15.02.2016	14:28:02	<input type="checkbox"/> 32

➔

Measurement date	Measurement time	Line number
15.02.2016	17:00:43	1235.7778

To cancel filtering, all steps should be taken in the reverse order.

- **Data grouping**

To group data for any of the fields, click the left mouse key on the header of the field column, and, with the mouse key pressed, drag it onto the table header:

Measurement date	Measurement time	Line number
15.02.2016	17:00:43	1235.7778
15.02.2016	16:56:29	1235.9450
15.02.2016	17:00:03	1235.9450
15.02.2016	14:28:02	32

➔

Measurement date		
Measurement date	Measurement time	Line number
+ Measurement date : 15.02.2016		

• **Changing of the field position order**



To change the field position, click the left mouse key on the header of the field column and, with the mouse key pressed, drag it to the required position:

Measurement date	Measurement time	Measurement date	Line number
15.02.2016	17:00:43	1235.7778	
15.02.2016	16:56:29	1235.9450	
15.02.2016	17:00:03	1235.9450	
15.02.2016	14:28:02	32	

➔

Measurement time	Measurement date	Line number
17:00:43	15.02.2016	1235.7778
16:56:29	15.02.2016	1235.9450
17:00:03	15.02.2016	1235.9450
14:28:02	15.02.2016	32

**Buttons:**

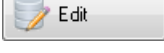
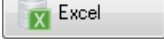
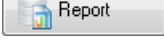
	Add a profile
	Delete the selected profile
	Delete all profiles
	Edit the selected profile
	Export the profile coordinates to the Excel format
	Report preparation

**22.2. Editing data**

You can edit, add and delete data in/from the database.

• **Editing data**

To edit the current entry, click  and input/change the values of parameters. Click the **Save** button.

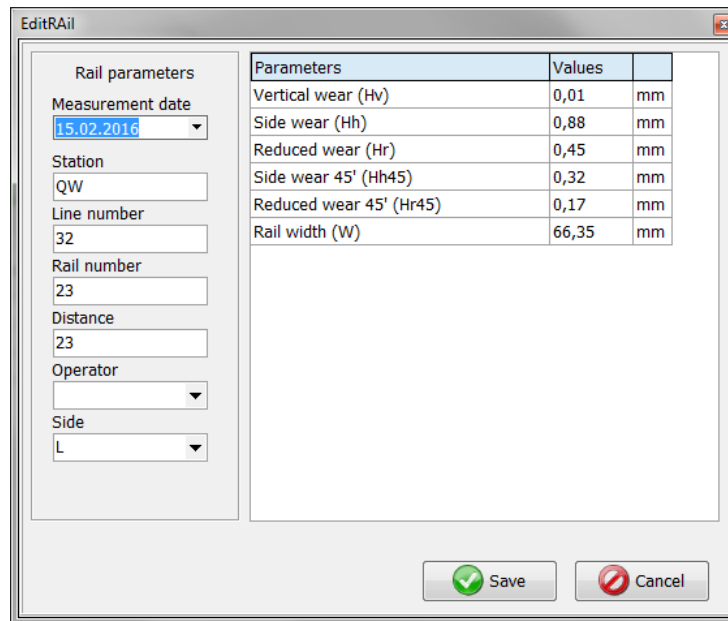

The screenshot shows the 'EditRAil' window with the following parameters and values:

Parameters	Values	
Vertical wear (Hv)	0,01	mm
Side wear (Hh)	0,88	mm
Reduced wear (Hr)	0,45	mm
Side wear 45' (Hh45)	0,32	mm
Reduced wear 45' (Hr45)	0,17	mm
Rail width (W)	66,35	mm

On the left side of the window, there are input fields for: Measurement date (15.02.2016), Station (QW), Line number (32), Rail number (23), Distance (23), Operator, Side (L), and buttons for Save and Cancel.

- **Adding data**

To add a new data entry, click  and type the values of parameters. Click the **Save** button.

- **Deleting data**

To delete the current entry, click  and confirm the deletion.

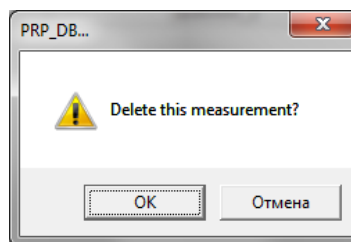

- **Deleting all selected data**

If it is necessary to delete not only one entry but several entries combined by some condition, filter the data according to the corresponding attribute (see par. [22.1](#)), click

 and confirm the deletion.

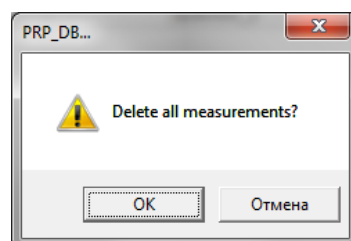

## 22.3. Report preparation

When staying in the mode of scanning and editing data, the user can prepare reports in **Excel**, **RTF**, **PDF** formats, or print out reports. When preparing the report, the sorting used at the moment is taken into account.

To generate a report, press the **Report** button. The program will offer to select the following options:

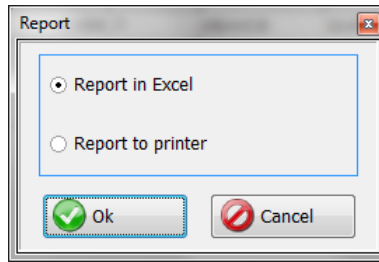

### 22.3.1. Excel-format report

To prepare a report in Excel format, select **Report in Excel** and click **OK**.

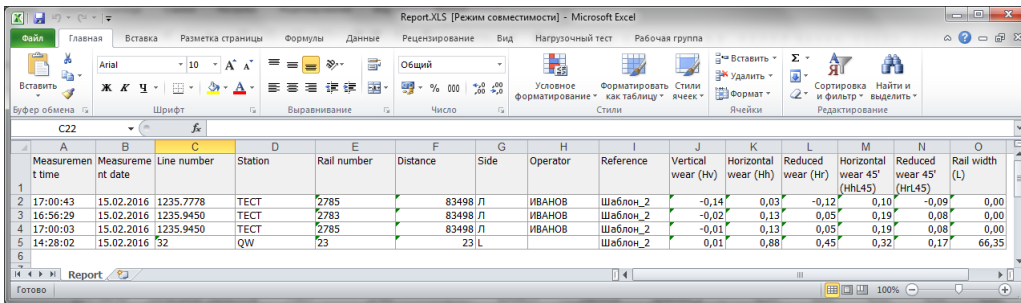

### 22.3.2. Report for printout

To prepare the report for printout, select **Report for printout** and click **OK**. Data will be presented in the form of report ready for printout.

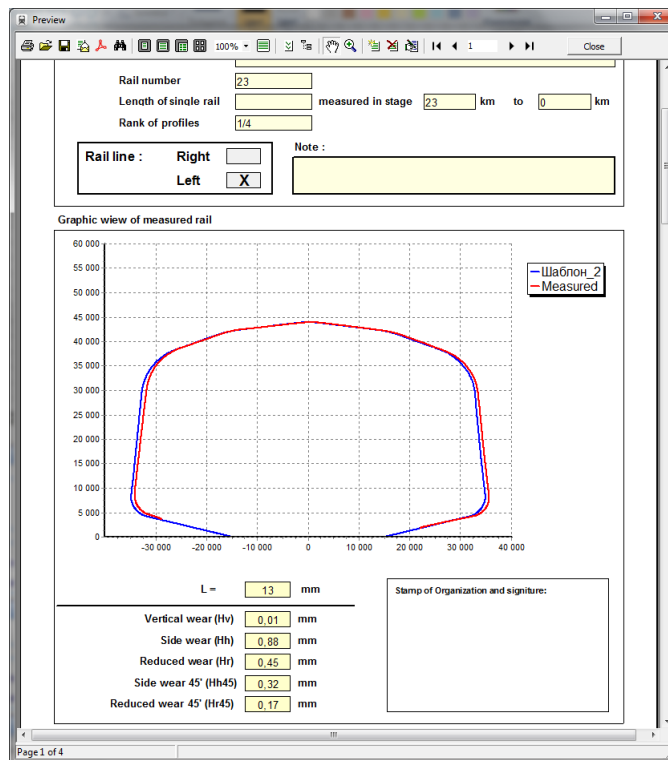

The top toolbar contains the following buttons for operating with reports:

- To printout the report, click
- To save in PDF format, click
- To save in Excel, RTF or PDF, click and select the format you need:

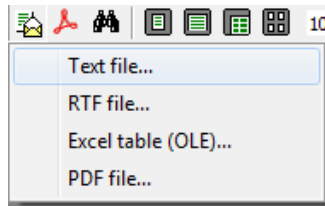

## 23. Taking measurements under PC control (without PDA)

The laser scanning module (RF570) can work under direct control of PC without PDA. To work under direct control of PC, it is necessary to select **File > Device > Profilometer**.

48

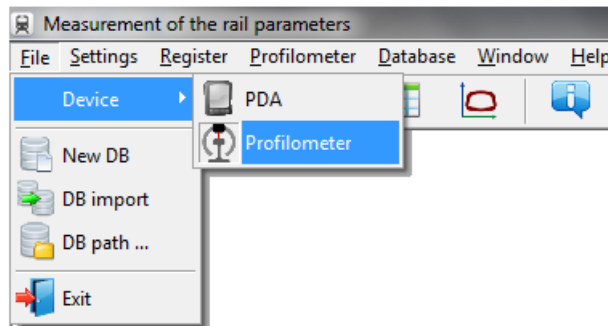

In the main menu of the program, the **PDA** tab will be replaced with the **Profilometer** tab.

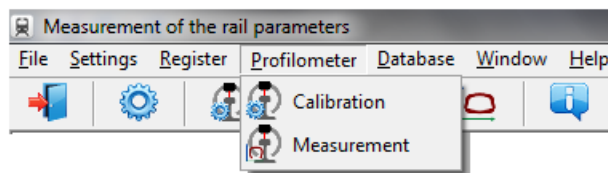

The menu contains two available items:

- Calibration
- Measurement

Before you start working with the profilometer, it is necessary to set the COM-port for Bluetooth-connection between the laser scanning module and PDA. The procedure is described in the User's manual that comes with the Bluetooth-adaptor.



## 23.1. Calibration

To calibrate the device, select **Profilometer > Calibration**, or click .

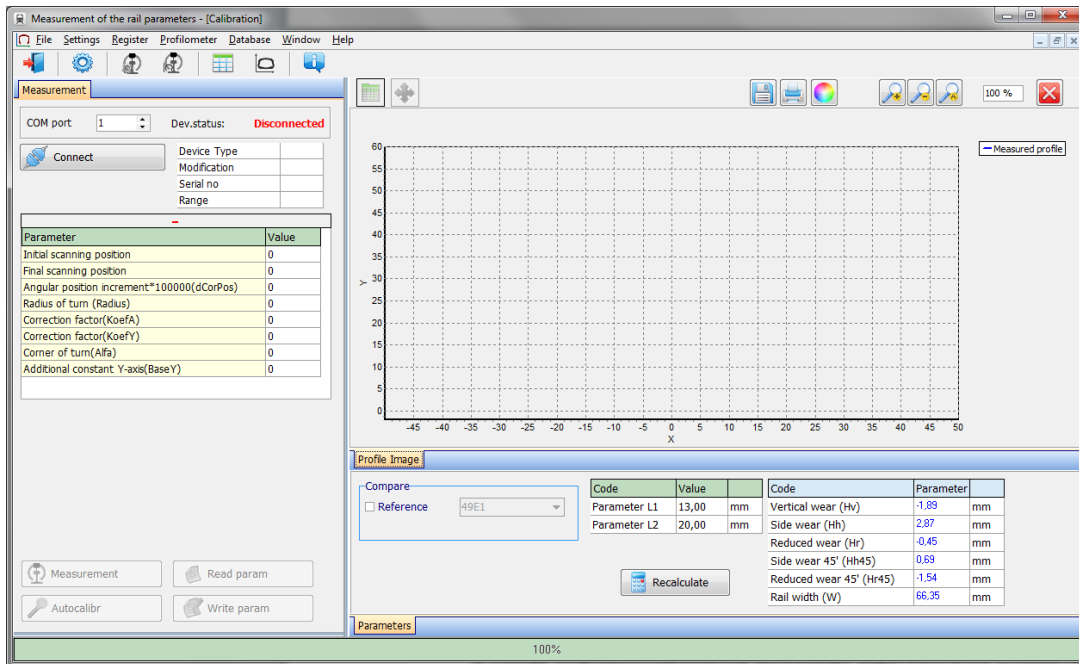

49

### 23.1.1. Bluetooth-connection

Select the COM-port and click the **Connect** button.

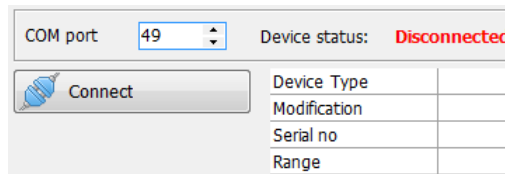



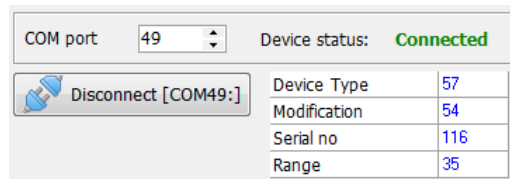

If the connection is successful, the device will be identified, and calibration parameters will be obtained. The status will be changed to **Connected**.



The table of calibration parameters:

Parameter	Value
Initial scanning position	1
Final scanning position	1955
Angular position increment*100000(dCorPos)	10856
Radius of turn (Radius)	5244
Correction factor(KoefA)	21
Correction factor(KoefY)	10000
Corner of turn(Alfa)	-87
Additional constant Y-axis(BaseY)	1000

## Buttons:

 Measurement	Measurement
 Read param	Reading calibration parameters
 Write param	Writing calibration parameters
 Autocalibr	Automatic setting of calibration parameters

 The **Auto calibration** button will be active, if at least one measurement of the profile is performed and the reference profile is selected.

50

### 23.1.2. Calibration of the profilometer

- Place the profilometer on the calibration block.
- Select the reference profile from the list (**Compare > Reference**).
- Perform the measurement (the **Measurement** button )
- Perform the calibration (the **Autocalibr** button).
- Save calibration parameters (the **Write param.** buton).

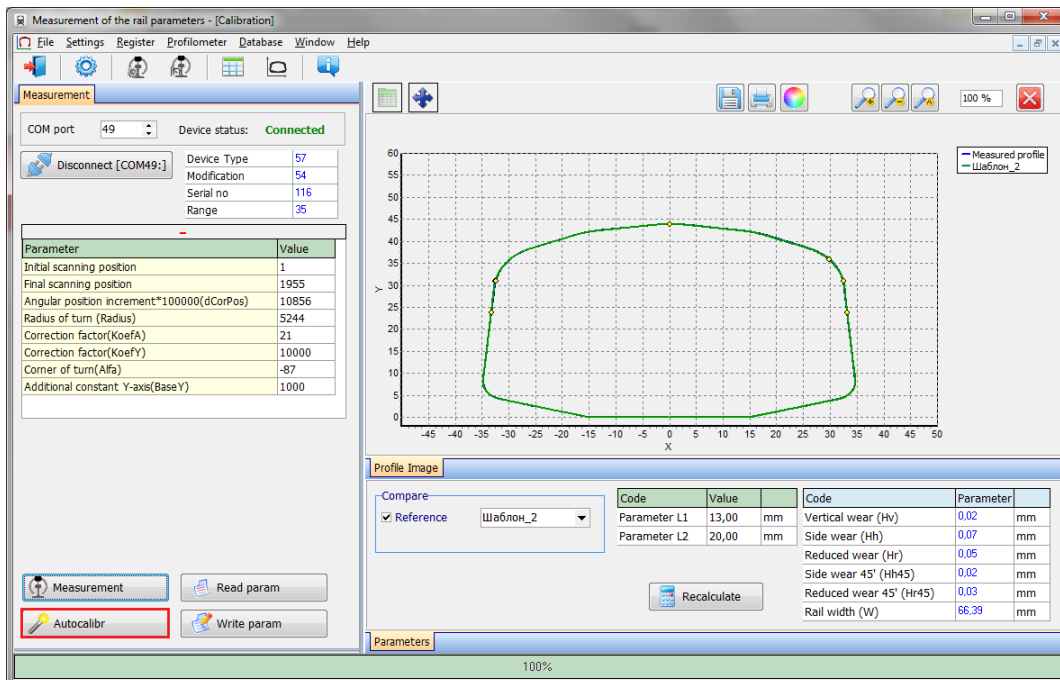

Parameter	Value
Initial scanning position	1
Final scanning position	1955
Angular position increment*100000(dCorPos)	10856
Radius of turn (Radius)	5244
Correction factor(KoeFA)	21
Correction factor(KoeFY)	10000
Corner of turn(Alfa)	-87
Additional constant Y-axis(BaseY)	1000

Code	Value	Code	Parameter
Parameter L1	13,00 mm	Vertical wear (Hv)	0.02 mm
Parameter L2	20,00 mm	Side wear (Hh)	0.07 mm
		Reduced wear (Hr)	0.05 mm
		Side wear 45' (Hh45)	0.02 mm
		Reduced wear 45' (Hr45)	0.03 mm
		Rail width (W)	66.39 mm

Calibration parameters can be set manually. To do it, click the left mouse key on the field of the required parameter value, and enter the new one.

 **Attention!** Writing incorrect values of some parameters can lead to the incorrect work of the device.

Buttons functions, work with profiles and calculation of required parameters are described in par. [21](#).

## 23.2. Measurement by using PC

Select **Profilometer > Measurement**, or click

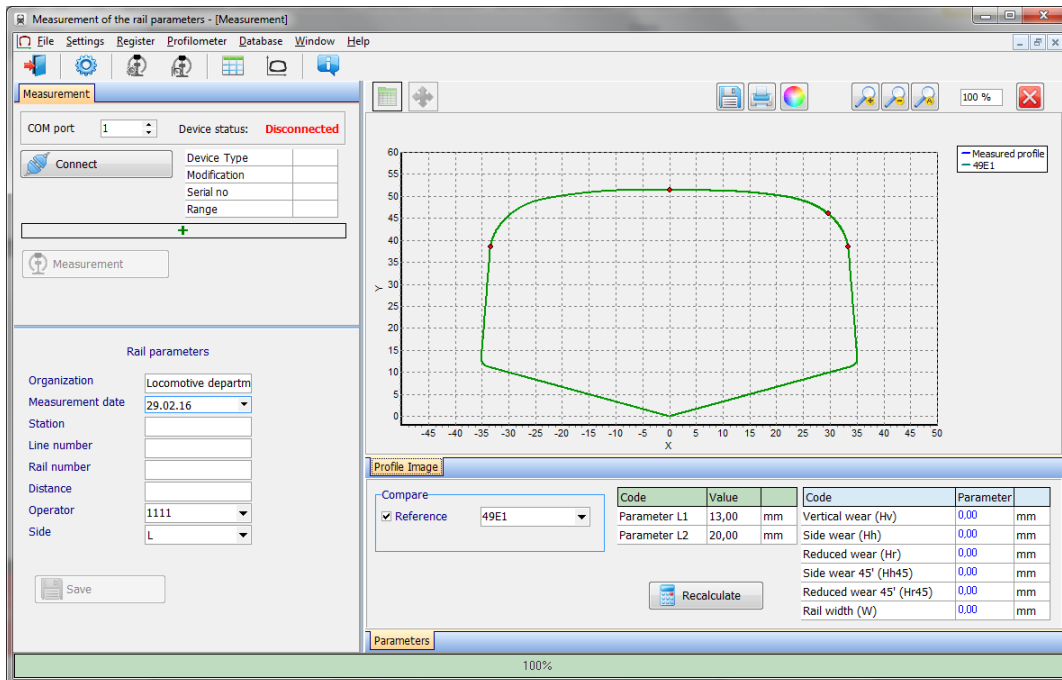

When the Bluetooth-connection is established (see par. [23.1.1](#)), the **Measurement** button is active.

### 23.2.1. Saving of data

- Place the profilometer on the rail
- Perform the measurement (the **Measurement** button)
- Enter the identification parameters of the rail

Rail parameters

Organization	Locomotive departm
Measurement date	29.02.16
Station	Station
Line number	7765.454
Rail number	1123
Distance	109900
Operator	2222
Side	L

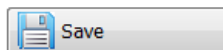

- To save results, click **Save**
- The measured profile will be saved to the database

Buttons functions, work with profiles and calculation of required parameters are described in par. [21](#).

## 24. Annex 1. Charging procedure

- Switch off the PDA (laser module).
- Connect the charging device to PDA (laser module).
- Connect the charging device to 220V AC.
- Time of charging: PDA - 4 hours, laser module - 5 hours. Full-charge indication: PDA - blue LED is lit; laser module - green LED is lit.
- Disconnect the charging device from 220V AC.
- Disconnect the charging device from PDA (laser module).



**Attention!** Please follow the sequence of these points.

## 25. Annex 2. Testing and calibration

We can supply the profilometer complete with the RF570.20.100 calibration-rail simulation unit (Fig. 1A) and the **RF570Calibr** calibration program, which are designed for periodic testing and calibration of the profilometer.

Instead of the calibration unit, use can be made of the rail with known profile entered to the database.

Before start the testing and calibration process, it is necessary to set the COM-port for Bluetooth-connection between the laser scanning module and PDA. The procedure is described in the user manual that comes with the Bluetooth-adapter.

### 25.1. Preparation for testing/calibration

- Install the **RF570Calibr** program on the PC.
- Install Bluetooth-connection between the scanning module and PC.
- Place the profilometer on the calibration unit.
- Start the **RF570Calibr** program.

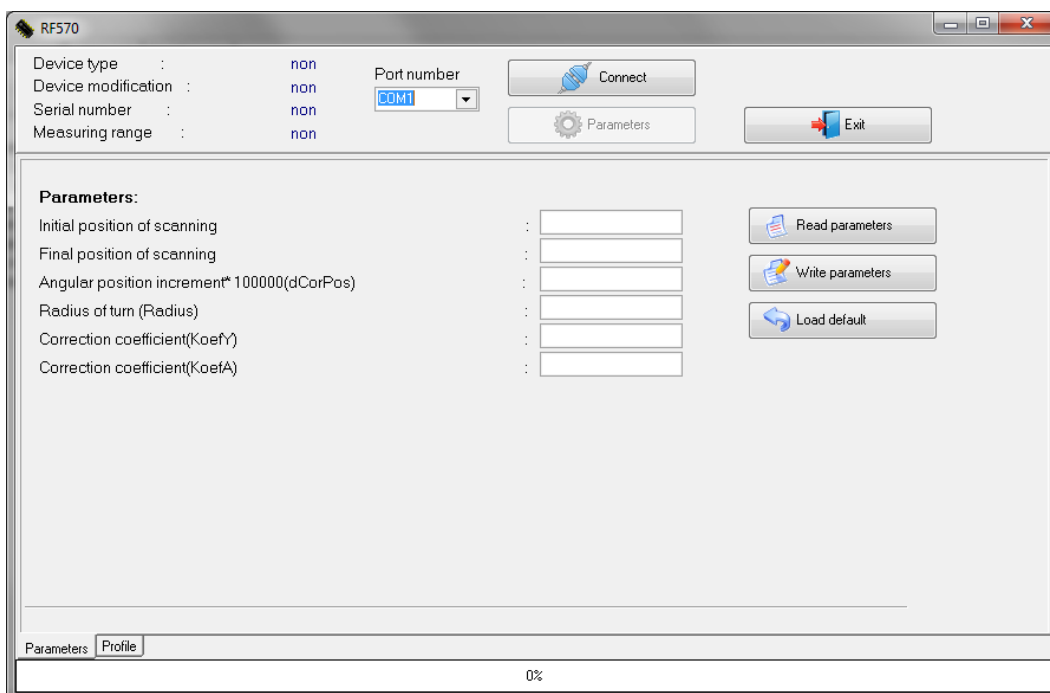

- To establish the Bluetooth-connection, select the required port.

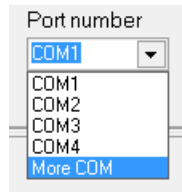

The device will be identified, and calibration parameters will be read.

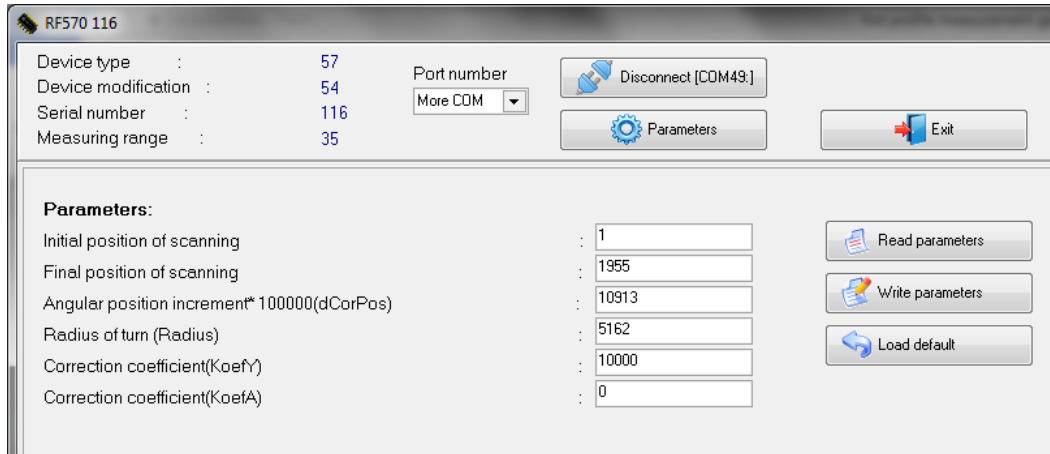

To perform the measurement:

- Go to the **Profile** tab.
- Select the reference profile: tick **Compare** and select the required reference profile from a drop-down list.
- Click the **Measurement** button.

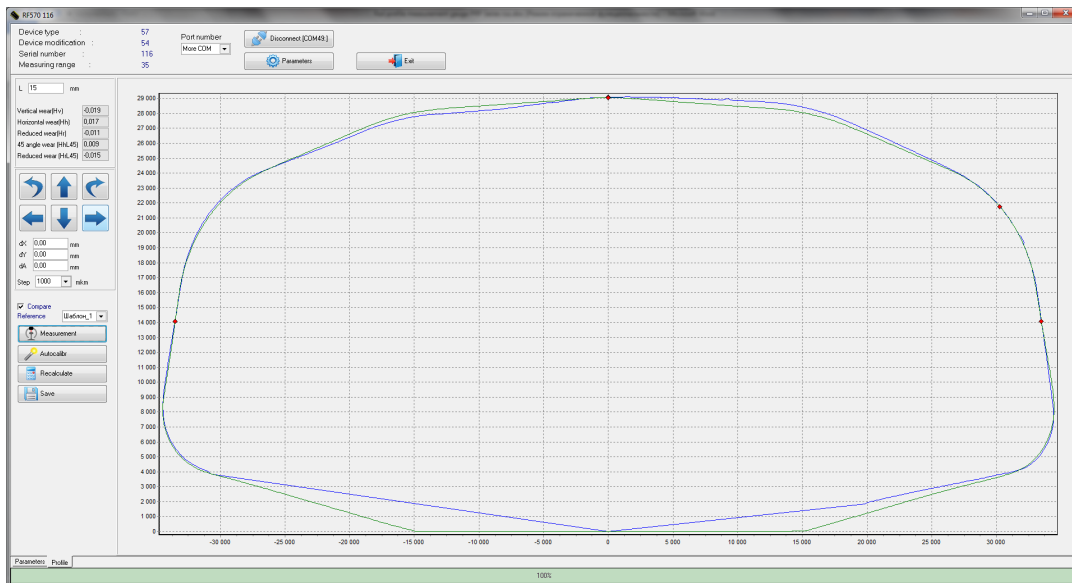

## 25.2. Calibration

To carry out the automatic calibration, follow the steps below:

- Select the reference profile from the list.
- Perform the measurement (the **Measurement** button).
- Perform the calibration (the **Autocalibr** button).
- Go to the **Parameters** tab and save parameters (the **Write parameters** button).

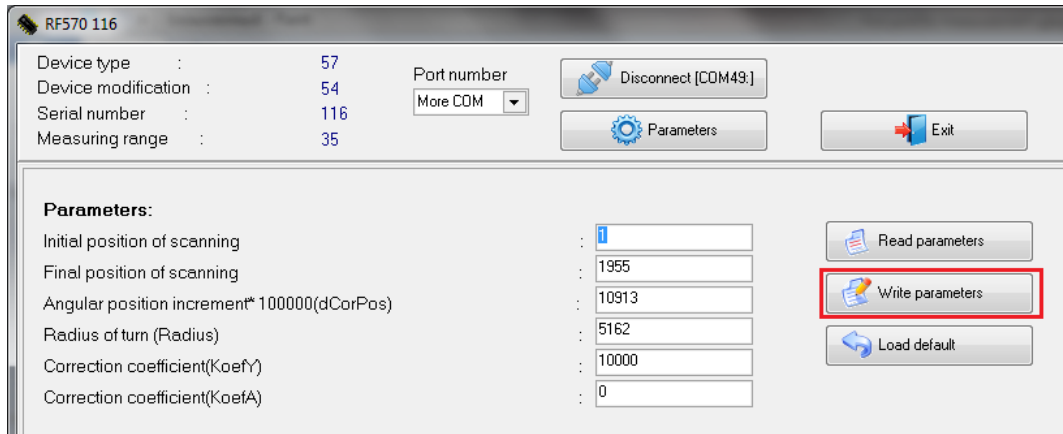

If, for some reason, the parameters have incorrect values (negative or zero), you must restore the factory settings by pressing the **Load default** button. After that, recalibrate the profilometer.

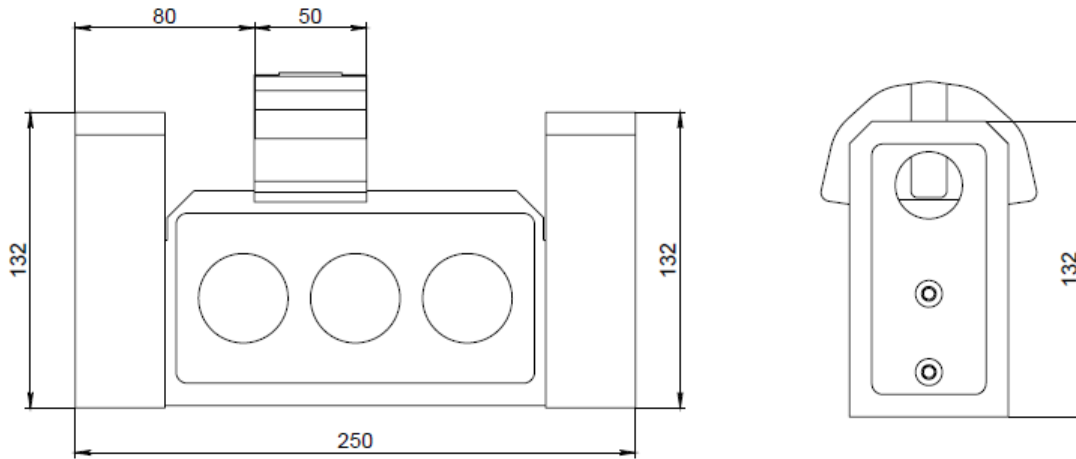

Figure 1A

## 26. Warranty policy

Warranty assurance for the Portable Rail Profilometer PRP Series - 24 months from the date of putting in operation; warranty shelf-life - 12 months.

## 27. List of changes

Date	Revision	Description
30.05.2012	1.0.0	Starting document.
15.03.2018	2.0.0	Updated the PRP description and the software description.

## 28. Distributors

### AUSTRIA

**MBM Industry & Rail Tech GmbH**

**RAILWAY INSTRUMENTS ONLY**

Tullnerbachstraße 36,  
A-3002 Purkersdorf, Austria  
Tel: +43 2231 66000  
Fax: +43 2231 66000 12  
[office@mbm-industrietechnik.at](mailto:office@mbm-industrietechnik.at)  
[www.mbm-tech.at](http://www.mbm-tech.at)

### AUSTRALIA

**Applied Measurement Australia Pty Ltd**

**RAILWAY INSTRUMENTS ONLY**

Thornton Plaza, Unit 5,  
27 Thornton Crescent, Mitcham  
VIC 3132, Australia  
Tel: +61 39874 5777  
Fax: +61 39874 5888  
[sales@appliedmeasurement.com.au](mailto:sales@appliedmeasurement.com.au)  
[www.appliedmeasurement.com.au](http://www.appliedmeasurement.com.au)

### BENELUX

**Althen Sensors & Controls BV**

Vietweg 17a  
2266KA Leidschendam  
The Netherlands  
Tel: +31 70 3924421  
Fax: +31 70 3644249  
[sales@althen.nl](mailto:sales@althen.nl)  
[www.althensensors.com](http://www.althensensors.com)  
[www.althencontrols.com](http://www.althencontrols.com)

### BULGARIA, HUNGARY

**RMT Ltd.**

R Zahradni 224  
739 21 Paskov, Czech Republic  
Tel: +420 558640211  
Fax: +420 558640218  
[rmt@rmt.cz](mailto:rmt@rmt.cz)  
[www.rmt.cz](http://www.rmt.cz)

### BRAZIL

**CAPI Controle e Automação Ltda**

Rua Itororó, 121, CEP 13466-240  
Americana-SP, Brazil  
Tel: +55 19 36047068  
Fax: +55 19 34681791  
[capi@capicontrol.com.br](mailto:capi@capicontrol.com.br)  
[www.capicontrol.com.br](http://www.capicontrol.com.br)

### CHILE

**Verne SpA**

Apoquindo 2818, oficina 31,  
Las Condes, Santiago, Chile  
Tel: +56 2 228858633  
[info@verne.cl](mailto:info@verne.cl)  
[jsaavedra@verne.cl](mailto:jsaavedra@verne.cl)  
[www.verne.cl](http://www.verne.cl)

### CHINA

**Zhenshangyou Technologies Co.,Ltd.**

Rm 2205-2210, Zhongyou Hotel  
1110 Nanshan Road, Nanshan  
District 518054 Shenzhen, China  
Tel: +86 755-26528100/8011/8012  
Fax: +86 755-26528210/26435640  
[info@51sensors.com](mailto:info@51sensors.com)  
[www.51sensors.com](http://www.51sensors.com)

### CHINA

**Shanghai micron-metrology com., Ltd.**

Room 602 unit 4, lane 399,  
Mudan road, Pudong New district  
Shanghai, China  
Tel: +86-21-68416510  
[sales@micron-metrology.cn](mailto:sales@micron-metrology.cn)  
[www.micron-metrology.cn](http://www.micron-metrology.cn)

### CHINA

**JRKtech Co., Ltd.**

1F, Building 9, 100 Xianlie Rd.,  
Guangzhou, China  
Tel: +86 755 85267190/  
+86 15989362481  
Fax: +86 755 85267190  
[shengz\\_k@163.com](mailto:shengz_k@163.com)  
[www.jrktech.com](http://www.jrktech.com)

### CZECH REPUBLIC

**RMT Ltd.**

Zahradni 224  
739 21 Paskov, Czech Republic  
Tel: +420 558640211  
Fax: +420 558640218  
[rmt@rmt.cz](mailto:rmt@rmt.cz)  
[www.rmt.cz](http://www.rmt.cz)

### FINLAND

**TERÄSPYÖRÄ-STEELWHEEL OY**

**RAILWAY INSTRUMENTS ONLY**

Juvan teollisuuskatu 28  
FI-02920 ESPOO, Finland  
Tel: +358 400 422 900  
Fax: +358 9 2511 5510  
[steelwheel@steelwheel.fi](mailto:steelwheel@steelwheel.fi)  
[www.teraspyora.fi](http://www.teraspyora.fi)

### FRANCE

**DB Innovation (ALTHEIS France)**

26, avenue de la Mediterranee  
34110 Frontignan France  
Tel: +33-467786166  
Fax: +33-467740134  
[dbi@altheris.fr](mailto:dbi@altheris.fr)  
[www.altheris.fr](http://www.altheris.fr)

**GERMANY**

**Disynet GmbH**  
Breyeller Str. 2  
41379, Brueggen  
Tel: +49 2157 8799-0  
Fax: +49 2157 8799-22  
[disynet@sensoren.de](mailto:disynet@sensoren.de)  
[www.sensoren.de](http://www.sensoren.de)

**GERMANY**

**Hylewicz CNC-Technik**  
**SHTRIKH-2 ONLY**  
Siemensstrasse 13-15,  
47608 Geldern, Germany  
Tel: +49 2831 91021-20  
Fax: +49 2831 91021-99  
[info@cnc-step.de](mailto:info@cnc-step.de)  
[www.cnc-step.de](http://www.cnc-step.de)

**INDONESIA**

**PT. DHAYA BASWARA**  
**SANIYASA**  
Botanic Junction Blok H-9 NO. 7  
Mega Kebon Jeruk, Joglo  
Jakarta 11640, Indonesia  
Tel: + 62 21 29325859  
[management@ptdbs.co.id](mailto:management@ptdbs.co.id)

**ITALY**

**FAE s.r.l.**  
Via Tertulliano, 41  
20137 Milano, Italy  
Tel: +39-02-55187133  
Fax: +39-02-55187399  
[fae@fae.it](mailto:fae@fae.it)  
[www.fae.it](http://www.fae.it)

**NORWAY**

**Salitec AS**  
PB 468,  
N-1327 Lysaker  
Tel.: +47 23 891015  
Fax: +47 92101005  
[mail@salitec.no](mailto:mail@salitec.no)  
[www.salitec.no](http://www.salitec.no)

**GERMANY**

**BIP-Industrietechnik GmbH**  
**RAILWAY INSTRUMENTS ONLY**  
Am Elisabethhof 22,  
D-14772 Brandenburg  
D-41379 Brueggen, Germany  
Tel: +49 (0) 33 81 75 90 0  
Fax: +49 (0) 33 81 75 90 11  
[info@bip-industrie.de](mailto:info@bip-industrie.de)  
[www.bip-industrietechnik.de](http://www.bip-industrietechnik.de)

**INDIA**

**Pragathi Solutions**  
#698, 5th Main, 8th Cross,  
HAL 3rd Stage,  
New Tippasandra Road,  
Bangalore, 560075, India  
Tel: +91 80 32973388  
Tel/fax: +91 80 25293985  
Mobile: +91 9448030426/  
+919448492380  
[sales@pragathisolutions.in](mailto:sales@pragathisolutions.in)  
[arghya@pragathisolutions.in](mailto:arghya@pragathisolutions.in)  
[www.pragathisolutions.in](http://www.pragathisolutions.in)

**IRAN**

**Novin Industrial**  
**Development Grp.**  
Tel: +98 21 44022093-6  
Fax: +98 21 43858794  
Mobile: +98 9123207518  
[info@novinid.com](mailto:info@novinid.com)  
[www.novinid.com](http://www.novinid.com)

**LATVIA, ESTONIA**

**SIA "SOLARTEX"**  
**RAILWAY INSTRUMENTS ONLY**  
Duntes 15a, 5th floor, office B7  
Riga, Latvia  
Tel.: +371 67 130 787  
[solartex@inbox.lv](mailto:solartex@inbox.lv)

**PERU**

**Verne Perú S.A.C.**  
Las Codornices 104,  
Surquillo, Lima, Peru  
Tel/fax: +51 992436734  
[info@verne.cl](mailto:info@verne.cl)  
[www.verne.cl](http://www.verne.cl)

**GERMANY**

**Finger GmbH & Co. KG**  
**OPTICAL MICROMETERS ONLY**  
Sapelloh 172,  
31606 Warmsen, Germany  
Tel: +49 5767 96020  
Fax: +49 5767 93004  
[finger@finger-kg.de](mailto:finger@finger-kg.de)  
[www.finger-kg.de](http://www.finger-kg.de)

**INDIA**

**Paragon Instrumentation**  
**Engineers Pvt. Ltd.**  
**RAILWAY INSTRUMENTS ONLY**  
200, Station Road,  
Roorkee, 247 667, India  
Tel: +91-1332-272394  
[tanuj@paragoninstruments.com](mailto:tanuj@paragoninstruments.com)  
[www.paragoninstruments.com](http://www.paragoninstruments.com)

**ISRAEL**

**Nisso Dekalo Import**  
**Export LTD**  
1 David Hamelech Street  
Herzia 46661 Israel  
Tel: +972-99577888  
Fax: +972-99568860  
[eli@fly-supply.net](mailto:eli@fly-supply.net)  
[www.fly-supply.net](http://www.fly-supply.net)  
[www.aircraft-partsupply.com](http://www.aircraft-partsupply.com)

**MALAYSIA**

**OptoCom InstruVentures**  
H-49-2, Jalan 5, Cosmoplex  
Industrial Park, Bandar Baru  
Salak Tinggi, Sepang, Malaysia  
Tel: 603 8706 6806  
Fax: 603 8706 6809  
[optocom@tm.net.my](mailto:optocom@tm.net.my)  
[www.optocom.com.my](http://www.optocom.com.my)

**POLAND**

**MTL ASCO Sp. z o.o.**  
**RAILWAY INSTRUMENTS ONLY**  
ul. Wielowiejska 53 44-120  
PYSKOWICE (k/ GLIWIC),  
Poland  
Tel: + 48 32 230 45 70  
Fax: + 48 32 332 70 14  
[rail@ascorail.eu](mailto:rail@ascorail.eu)  
[www.ascorail.eu](http://www.ascorail.eu)



**PORTUGAL****UltraSens**

Qt. da Portela, Lt. 22.1, Ap. 152  
3030 - 502 Coimbra, Portugal  
Phone +351 239 796 277  
Fax: +351 239 918 267  
[info@ultrasens.com](mailto:info@ultrasens.com)  
[www.ultrasens.com](http://www.ultrasens.com)

**SERBIA, SLOVAKIA****RMT Ltd.**

Zahradni 224  
739 21 Paskov, Czech Republic  
Tel: +420 558640211  
Fax: +420 558640218  
[rmt@rmt.cz](mailto:rmt@rmt.cz)  
[www.rmt.cz](http://www.rmt.cz)

**SPAIN****Iberfluid Instruments S.A.**

C/ Botanica, 122  
08908 L'Hospitalet de Llobregat,  
Barcelona  
Tel: +34 93 447 10 65  
Fax: +34 93 334 05 24  
[myct@iberfluid.com](mailto:myct@iberfluid.com)  
[www.iberfluid.com](http://www.iberfluid.com)

**SWEDEN, DENMARK****Latronix AB**

Propellervagen 10,  
183 62 Täby, Sweden  
Tel.: +46 08-446 48 30  
Fax: +46 08-446 48 39  
[sales@latronix.se](mailto:sales@latronix.se)  
[www.latronix.se](http://www.latronix.se)

**UKRAINE****KODA**

Frunze st 22  
61002, Harkov, Ukraine  
Tel/fax: +38 057 714 26 54  
[mail@koda.com.ua](mailto:mail@koda.com.ua)  
[www.koda.com.ua](http://www.koda.com.ua)

**RUSSIA****Sensorika-M LLC**

Dmitrovskoye shosse 64-4  
127474, Moscow, Russia  
Tel: +7 499 487 0363  
Fax: +7 499 487 7460  
[info@sensorika.com](mailto:info@sensorika.com)  
[www.sensorika.com](http://www.sensorika.com)

**SOUTH AFRICA****Ratcom Enterprise Pty Ltd**

CSIR BUILDING 35, Office 78  
Meiring Naude Road, Brummeria  
Pretoria, 0084 South Africa  
Tel: + 27 12 841 2032  
Fax: + 27 86 225 0650  
[info@ratcom.co.za](mailto:info@ratcom.co.za)  
[www.ratcom.co.za](http://www.ratcom.co.za)

**SWITZERLAND****ID&T GmbH**

Gewerbestrasse 12/a  
8132 Egg (Zurich), Switzerland  
Tel: + 41 44 994 92 32  
Fax: + 41 44 994 92 34  
[info@idtlaser.com](mailto:info@idtlaser.com)  
[www.idtlaser.com](http://www.idtlaser.com)

**THAILAND****Advantech Solution Co.,Ltd.**

20/170 Motorway Rd.,  
Kwang Pravet, Khet Pravet,  
Bangkok, Thailand 10250  
Tel: +662-1848705  
Fax: +662-1848708  
[sales@advantechsolution.com](mailto:sales@advantechsolution.com)  
[www.advantechsolution.com](http://www.advantechsolution.com)

**UNITED KINGDOM,  
IRELAND****Ixthus Instrumentation Ltd**

The Stables, Williams' Barns  
Tiffield road, Towcester, Northants  
Tel: +44 1327 353437  
Fax: +44 1327 353564  
[info@ixthus.co.uk](mailto:info@ixthus.co.uk)  
[www.ixthus.co.uk](http://www.ixthus.co.uk)

**RUSSIA****Diesel-test-Komplekt LLC**

620030, Karjernaya St, 16  
Ekaterinburg, Russia  
Tel/fax: +7 343 2227565  
Tel/fax: +7 343 2227370  
[mail@d-test.ru](mailto:mail@d-test.ru)  
[www.d-test.ru](http://www.d-test.ru)

**SOUTH KOREA****PROSEN. CO., LTD**

M-1001, Songdo techno park IT  
center, 32, Songdogwahak-ro,  
Yeonsu-gu, Incheon, 21984,  
Republic of Korea  
Tel: +82-32-811-3457  
Fax: +82-32-232-7458  
[trade@prosen.co.kr](mailto:trade@prosen.co.kr)  
[www.prosen.co.kr](http://www.prosen.co.kr)

**SWEDEN, DENMARK****BLConsult**

Ryssbält 294,  
95 291 KALIX, Sweden  
Mobile: +46 70 663 19 25  
[info@blconsult.se](mailto:info@blconsult.se)  
[www.blconsult.se](http://www.blconsult.se)

**TURKEY****TEKMA Mühendislik A.S.**

Cevizi Mh. M. Kemal Cd.,  
Hukukçular Towers,  
A-Blok, No: 66-A/39  
Kartal – Istanbul  
Tel: +90 216 970 1318  
Tel: +90 850 840 2334  
[info@tekma.eu](mailto:info@tekma.eu)  
[www.tekma.eu](http://www.tekma.eu)

**USA, CANADA, MEXICO****International Electronic  
Machines Corporation  
RAILWAY INSTRUMENTS ONLY**

850 River Street, Troy,  
New York, USA  
Tel: +1 518 268-1636  
Fax: +1 518 268-1639  
[marketing@iem.net](mailto:marketing@iem.net)  
[www.iem.net](http://www.iem.net)

USA, CANADA, MEXICO

**Acuity Products of Schmitt Industries, Inc.**

2765 NW Nicolai Street  
Portland, OR, 97210, USA  
Tel: +1 503 227 7908  
Fax: +1 503 223 1258  
[sales@acuitylaser.com](mailto:sales@acuitylaser.com)  
[www.acuitylaser.com](http://www.acuitylaser.com)

## 29. RIFTEK's measurement devices for railway transport

58

### Laser wheel profilometer. IKP Series

A laser profilometer is designed for the measuring of:

- wheel flange height;
- wheel flange thickness;
- wheel flange slope;
- full profile scanning and analyze of wheel rolling surface;
- maintaining of electronic wear data base;
- control of tolerances and sorting in the course of checkup, examination, repair and formation of railway wheel sets.

Measurements are made directly on rolling stock without wheel set roll-out.



### Portable laser rail profilometer. PRP Series

The main functions of PRP are:

- obtaining the information on the cross-section profile of the working railhead surface;
- full profile scanning and analyze of the railhead acting face;
- visualization of the combined graphical images of actual and new cross-section railhead profiles on the display of system unit.



### Wheel diameter measuring gauge. IDK Series

Electronic gauge is designed for measuring wheel rolling circle diameter of railway, metro and tram wheel sets.

Measurements are made directly on rolling stock without wheel set roll-out.





**Back-to-back distance measuring gauge. IMR Series**

Gauge is designed for contactless measuring of back-to-back distance of railway, metro and tram wheels in the course of checkup, examination, repair and formation of wheel sets.

Measurements are made directly on rolling stock without wheel set roll-out.



**Back-to-back distance measuring gauge. IMR-L Series**

Gauge is designed for contactless measuring of back-to-back distance of railway, metro and tram wheels in the course of checkup, examination, repair and formation of wheel sets.

Measurements are made directly on rolling stock without wheel set roll-out.



**Disc brakes profile gauge, IKD Series**

Laser disc brakes profilometer IKD Series is designed for disc brakes profile measuring.

The main functions of IKD are:

- obtaining the information on the profile parameters of the working disc brakes surface;
- full profile scanning and analyze of the disc brakes acting face;
- visualization of the combined graphical images of actual and new disc brakes profiles on the display of system unit.



**Automatic real-time system for measurement of wheelsets geometrical parameters**

The system is designed for contactless automatic measurement of geometrical parameters of railway wheels and uses a combination of 2D laser scanners, mounted wayside in the track area.

The system can be easily installed at any type of rail infrastructure.